

ORANGE COUNTY BOARD OF SUPERVISORS

Agenda Revisions and Supplementals

Note: *This supplemental agenda is updated daily showing items that have been added, continued, deleted or modified.
No new supplemental items will be added to the agenda following close of business on Friday.*

April 13, 2021

DISCUSSION

36. Revised Title to read:
OC Waste & Recycling - Approve Mitigation Agreement with Irvine Ranch Conservancy to restore, create and manage habitat within Trabuco Creek, O'Neil Regional Park, 10 year term (\$4,508,200); approve Trabuco Creek Endowment Funding agreement with Orange County Community Foundation for long term management of Trabuco Creek Mitigation Site (\$2,274,124); *and* authorize Director or designee to execute agreements; ~~and consider application of Final Environmental Impact Report No. 575 and Addendum 575-8 and other findings~~ - District 5
37. Deleted
41. Revised Title to read:
County Executive Office - Approve grant applications/awards submitted by *Health Care Agency and Sheriff-Coroner* in 4/13/21 grant report and other actions as recommended - All Districts

PUBLIC HEARING

45. Continued to 5/11/21, 9:30 a.m.

THE FOLLOWING AGENDA ITEMS HAVE HAD CHANGES TO THEIR RECOMMENDED ACTIONS SINCE RELEASE OF THE AGENDA TO THE PUBLIC:

Items: 36 and 41

S u p p l e m e n t a l I t e m (s)

- S43A. **Clerk of the Board** - Approve revised 2021 Chairman's appointments of Board Members to various Boards, Commissions and Committees; and adopt revised California Form 806 - Agency Report of Public Official Appointments - All Districts
- S43B. **Supervisor Foley** - Orange County Veterans Advisory Council - Appoint Alexander Gonzalez, Costa Mesa, for term ending 1/2/23
- S43C. **Supervisor Foley** - Orange County Parks Commission - Appoint Michael Wellborn, Fountain Valley, for term concurrent with 2nd District Supervisor's term of office
- S43D. **Supervisor Foley** - Orange County Human Relations Commission - Appoint Ada Briceño, Stanton, for term ending 4/12/23
- S43E. **Supervisor Foley - Acting as the Orange County Housing Authority** - Housing and Community Development Commission - Appoint Muriel Ullman, Newport Beach, to complete term ending 6/30/21

REVISIONS AND SUPPLEMENTALS TO APRIL 13, 2021 AGENDA - PAGE 1 OF 2

ORANGE COUNTY BOARD OF SUPERVISORS

A g e n d a R e v i s i o n s a n d S u p p l e m e n t a l s

Note: *This supplemental agenda is updated daily showing items that have been added, continued, deleted or modified.*

No new supplemental items will be added to the agenda following close of business on Friday.

- S43F. **Supervisor Foley** - John Wayne Airport Arts Commission - Appoint David Lee, Corona Del Mar, for term concurrent with 2nd District Supervisor's term of office
- S43G. **Supervisor Foley** - Emergency Medical Care Committee - Appoint Lawrence Grihalva, Fountain Valley, to complete term ending 6/30/21
- S43H. **Supervisor Foley** - Community Action Partnership of Orange County - Appoint Rev. Rayna Hamre, Huntington Beach, for term concurrent with 2nd District Supervisor's term of office
- S43I. **Supervisor Foley** - Orange County Airport Commission - Appoint Susan Dvorak, Newport Beach, for term concurrent with 2nd District Supervisor's term of office
- S45A. **County Executive Office - Acting as the Orange County Flood Control District** - Public Hearing to consider adopting Resolutions of Necessity acquiring by eminent domain real property for Santa Ana River Mainstem/Prado Dam Project located in San Bernardino County; authorizing County Counsel and/or outside eminent domain counsel to take steps to initiate and facilitate the condemnation action; directing and authorizing Auditor-Controller to make related payments; and considering application of Final Environmental Impact Report No. 583 and Final Supplemental Environmental Impact Statement/Environmental Impact Report 583 and other findings - All Districts (2/3 vote of membership)
- SCS2. **County Counsel** - CONFERENCE WITH LEGAL COUNSEL - EXISTING LITIGATION - Pursuant to Government Code Section 54956.9(d)(1):
Name of Case: Mark Chew v. County of Orange WCAB Case Number: unassigned
- SCS3. **County Counsel** - CONFERENCE WITH LEGAL COUNSEL - ANTICIPATED LITIGATION - SIGNIFICANT EXPOSURE TO LITIGATION - Pursuant to Government Code Section 54956.9(d)(2):
Number of Cases: Four Cases
- SCS4. **County Counsel** - CONFERENCE WITH LEGAL COUNSEL - EXISTING LITIGATION - Pursuant to Government Code Section 54956.9(d)(1):
Name of Case: City of Santa Ana v. County of Orange, United States District Court Case No. 8:20-cv-00069-DOC-DFM
- SCS5. **County Counsel** - CONFERENCE WITH LEGAL COUNSEL - EXISTING LITIGATION - Pursuant to Government Code Section 54956.9(d)(1):
Name of Case: Orange County Flood Control District v. John Bos and Andy Bos, Trustees of the Bos Grandchildrens' Trust, et al., San Bernardino County Superior Court Case No. CIVDS1936248
- SCS6. **County Counsel** - CONFERENCE WITH LEGAL COUNSEL - INITIATION OF LITIGATION - Pursuant to Government Code Section 54956.9(d)(4):
Number of Cases: One. City of Santa Ana v. Orange County Association for Mental Health dba Mental Health Association of Orange County, Orange County Superior Court case no. 30-2020-01124174 (2/3 vote of members present)



Revision to ASR and/or Attachments

Date: March 30, 2020
To: Clerk of the Board of Supervisors
CC: County Executive Office *Frank Kim*
From: Tom Koutroulis, Director, OC Waste & Recycling
Re: ASR Control #: 21-000123, Meeting Date 4/13/21, Item No. # 36
Subject: Approve Habitat Mitigation and Endowment Agreements for Prima Deshecha Landfill

Digitally signed by Frank Kim
 DN: cn=Frank Kim, ou=County of Orange, ou=CEO,
 email=frank.kim@ocgov.com,
 c=US
 Date: 2021.04.01 16:59:45 -0700

Frank Kim

RECEIVED
 CLERK OF THE BOARD

APR 02 2021

Explanation: Remove Recommended Action Number One. The Environmental Impact Report (EIR) was previously approved by Board of Supervisors, therefore a new finding is not needed in the recommended actions for this Agenda Staff Report.

Revised Recommended Action(s)

1. ~~Find that Final Environmental Impact Report No. 575, previously certified by the Board of Supervisors on November 6, 2001, in combination with Addendum No. 575-8, certified by the Director of OC Waste & Recycling on November 7, 2018, reflects the independent judgment of the County of Orange and satisfies the requirements of CEQA for the proposed project, which is a necessarily included element contemplated as part of this action.~~
- 1.-2. Authorize the Director of Orange County Waste & Recycling or designee to execute the Mitigation Agreement for the Short and Long-Term Management of the Trabuco Creek Mitigation Site with the Irvine Ranch Conservancy, in the amount not to exceed \$4,508,200, with an initial payment of up to \$347,600 in FY 2020-21 to restore, create, and manage the habitat within Trabuco Creek at O'Neil Regional Park over a term of up to 10 years.
2. 3. Authorize the Director of Orange County Waste & Recycling or designee to execute the Trabuco Creek Endowment Funding Agreement for the Long-Term Management of the OC Waste & Recycling Trabuco Creek Mitigation Site with the Orange County Community Foundation and make payment of \$2,274,124 in FY 2020-21 from Enterprise Fund 299 for the creation of the Endowment Funding Agreement for the Long-Term Management of the OC Waste & Recycling Trabuco Creek Mitigation Site.

Make modifications to the:

- Subject Background Information Summary Financial Impact



AGENDA STAFF REPORT

Agenda Item

41

ASR Control 21-000057

MEETING DATE: 04/13/21
LEGAL ENTITY TAKING ACTION: Board of Supervisors
BOARD OF SUPERVISORS DISTRICT(S): All Districts
SUBMITTING AGENCY/DEPARTMENT: County Executive Office (Approved)
DEPARTMENT CONTACT PERSON(S): Peter DeMarco (714) 834-5777
 Cynthia Shintaku (714) 834-7086

SUBJECT: Grant Applications/Awards Report

CEO CONCUR Concur	COUNTY COUNSEL REVIEW No Legal Objection	CLERK OF THE BOARD Discussion 3 Votes Board Majority
-----------------------------	--	---

Budgeted: N/A **Current Year Cost:** N/A **Annual Cost:** N/A
Staffing Impact: No **# of Positions:** **Sole Source:** N/A
Current Fiscal Year Revenue: N/A
Funding Source: N/A **County Audit in last 3 years:** No

Prior Board Action: N/A

RECOMMENDED ACTION(S):

Approve grant applications/awards as proposed and other actions as recommended.

1. Approve Grants Award – Health Care Agency – State of California Emergency Solutions Grants (ESG) Program, Coronavirus Aid, Relief and Economic Security (CARES) Act Funds – \$18,207,901.
2. Approve Grant Application – Health Care Agency – Health and Human Services Advancing Health Literacy to Engage Equitable Community Responses to COVID-19 – \$4,000,000.
3. Approve Grant Application – Health Care Agency – Children’s Dental Disease Prevention Program/Local Oral Health Program (LOHP) – \$100,000.
4. Approve Grant Award – Health Care Agency – HIV Emergency Relief Project Grants - Ryan White Part A – \$6,292,035.
5. Approve Grant Application – Sheriff-Coroner’s Department – Tobacco Grant Program – \$800,000.
6. Approve Grant Application – Sheriff-Coroner’s Department – Surrendered and Abandoned Vessel Exchange (SAVE) Grant – \$60,000.

7. Approve Grant Application – Sheriff-Coroner’s Department – State Criminal Alien Assistance Program – \$2,500,000.
8. Approve Grant Award – Sheriff-Coroner’s Department – Paul Coverdell Forensic Science Improvement Grants Program – \$95,746.
9. Receive and File Grant Report.

SUMMARY:

See the attached Grants Report.

BACKGROUND INFORMATION:

See the attached Grants Report.

FINANCIAL IMPACT:

N/A

STAFFING IMPACT:

N/A

ATTACHMENT(S):

Attachment A-Grants Report



Grants Report

DRAFT

County Executive Office/Legislative Affairs

April 13, 2021
Item No : 41

County of Orange Report on Grant Applications/Awards

The Grants Report is a condensed list of grant requests by County Agencies/Departments that allows the Board of Supervisors to discuss and approve grant submittals in one motion at a Board meeting. County policy dictates that the Board of Supervisors must approve all grant applications prior to submittal to the grantor. This applies to grants of all amounts, as well as to new grants and those that have been received by the County for many years as part of an ongoing grant. Receipt of grants \$50,000 or less is delegated to the County Executive Officer. Grant awards greater than \$50,000 must be presented to the Board of Supervisors for receipt of funds. This report allows for better tracking of county grant requests, the success rate of our grants, and monitoring of County's grants activities. It also serves to inform Orange County's Sacramento and Washington, D.C. advocates of County grant activities involving the State or Federal Governments.

On April 13, 2021 the Board of Supervisors will consider the following actions:

RECOMMENDED ACTIONS

Approve grant applications/awards as proposed and other actions as recommended.

ACTION ITEMS:

1. Approve Grants Award – Health Care Agency – State of California Emergency Solutions Grants (ESG) Program, Coronavirus Aid, Relief and Economic Security (CARES) Act Funds – \$18,207,901.
2. Approve Grant Application – Health Care Agency – Health and Human Services Advancing Health Literacy to Engage Equitable Community Responses to COVID-19 – \$4,000,000.
3. Approve Grant Application – Health Care Agency – Children's Dental Disease Prevention Program/Local Oral Health Program (LOHP) – \$100,000.
4. Approve Grant Award – Health Care Agency – HIV Emergency Relief Project Grants - Ryan White Part A – \$6,292,035.
5. Approve Grant Application – Sheriff-Coroner's Department – Tobacco Grant Program – \$800,000.
6. Approve Grant Application – Sheriff-Coroner's Department – Surrendered and Abandoned Vessel Exchange (SAVE) Grant – \$60,000.
7. Approve Grant Application – Sheriff-Coroner's Department – State Criminal Alien Assistance Program – \$2,500,000.

8. Approve Grant Award – Sheriff-Coroner's Department – Paul Coverdell Forensic Science Improvement Grants Program – \$95,746.
9. Receive and File Grants Report.

If you or your staff have any questions or require additional information on any of the items in this report, please contact Cynthia Shintaku at 714-834-7086



**CEO-Legislative Affairs Office
Grant Authorization eForm**

GRANT APPLICATION / GRANT AWARD

Today's Date:	March 17, 2021
Requesting Agency/Department:	Health Care Agency Office of Care Coordination
Grant Name and Project Title:	State of California Emergency Solutions Grants (ESG) Program, Coronavirus Aid, Relief and Economic Security (CARES) Act Funds
Sponsoring Organization/Grant Source: <small>(If the grant source is not a government entity, please provide a brief description of the organization/foundation)</small>	State of California Department of Housing and Community Development
Application Amount Requested:	\$18,207,901
Application Due Date:	October 28, 2020
Board Date when Board Approved this Application:	October 20, 2020
Awarded Funding Amount:	\$18,207,901
Notification Date of Funding Award:	February 19, 2021
Is this an Authorized Retroactive Grant Application/Award? No. <small>(If yes, attach memo to CEO)</small>	
Recurrence of Grant	New <input type="checkbox"/> Recurrent <input checked="" type="checkbox"/> Other <input type="checkbox"/> Explain:
If this is a recurring grant, please list the funding amount applied for and awarded in the past:	Each allocation is a new grant award. The previous grants awarded were 2018: \$584,187 2019: \$605,188 2020: \$640,283 ESG-CV1: \$2,444,700
Does this grant require CEQA findings?	Yes <input type="checkbox"/> No <input checked="" type="checkbox"/>
What Type of Grant is this?	Competitive <input type="checkbox"/> Other Type <input checked="" type="checkbox"/> Explain: State designated Administrative Entity.
County Match?	Yes <input type="checkbox"/> Amount ____ or __ % No <input checked="" type="checkbox"/>
How will the County Match be Fulfilled? <small>(Please include the specific budget)</small>	N/A
Will the grant/program create new part or full-time positions?	No.
Purpose of Grant Funds:	Provide a summary and brief background of why Board of Supervisors why should accept this grant application/award, and how the grant will be implemented.
<p>The Emergency Solutions Grants (ESG) Program provides funding to (1) engage individuals and families experiencing unsheltered homelessness; (2) improve the number and quality of emergency shelters for individuals and families experiencing homelessness; (3) help operate these shelters; (4) provide essential services to participants of shelter programs; (5) rapidly re-house individuals and families experiencing homelessness; and (6) prevent families and individuals from becoming homeless.</p> <p>On March 30, 2016, the State Department of Housing and Community Development (HCD) approved the County of Orange (County), in collaboration with the Orange County Continuum of Care (CoC), as the Administrative Entity (AE) for allocation of ESG funding.</p> <p>On March 27, 2020, Congress passed the Coronavirus Aid, Relief and Economic Security (CARES) Act. The CARES Act identified additional funding for ESG Program, the Community Development Block Grant (CDBG) Program, and the Housing Opportunities for Persons with AIDS (HOPWA) Program to support preparation for and response to the community impacts of the COVID-19 pandemic. The distribution plan of the U.S. Department of</p>	



**CEO-Legislative Affairs Office
Grant Authorization eForm**

Housing and Urban Development (HUD) for the additional funding includes multiple phases to address the immediate crisis resulting from the rising pandemic and post-pandemic community recovery.

On May 11, 2020, HCD announced the release of the ESG Program CARES Act (ESG-CV1) Notice of Funding Availability (NOFA) for the first allocation. The Orange County CoC received an allocation amount of \$2,444,700, which includes the County as the AE retaining \$128,700 for grant administration and the remaining amount of \$2,316,000 available for homeless prevention, emergency shelter, rapid rehousing, and other related eligible activities. The Health Care Agency (HCA) Office of Care Coordination pursued this grant opportunity to bring funding and resources to provide rapid rehousing services for individuals and families experiencing homelessness. The Board of Supervisors (Board) authorized HCA to apply for ESG-CV1 funding on June 23, 2020. The application was submitted to HCD on July 17, 2020. On September 17, 2020, HCA received an award announcement letter of ESG-CV1 funding for eligible program activities. On October 6, 2020, the Board authorized HCA to accept the ESG-CV1 grant award and execute the Standard Agreement. The Standard Agreement was issued and executed by State HCD on December 24, 2020.

On October 2, 2020, HCD announced the release of the ESG Program, CARES Act Funds (ESG-CV2) NOFA for the second allocation. The Orange County CoC allocation in the amount of \$18,207,901 includes the County as the AE retaining \$587,400 for grant administration and the remaining amount of \$17,620,501 prioritized for emergency shelter, rapid rehousing and related eligible activities for individuals and families experiencing homelessness. The NOFA provides documentation requirements for AEs approved to administer ESG-CV funding. The Health Care Agency (HCA) Office of Care Coordination pursued this grant opportunity to bring additional funding and resources to support individuals and families experiencing homelessness impacted by COVID-19. On October 20, 2020, the Board authorized HCA to apply for ESG-CV2 funding. HCA submitted the ESG-CV2 application by the HCD deadline of October 28, 2020.

On February 19, 2021, HCA received an award announcement letter of ESG-CV2 funding for eligible program activities. HCA is bringing the award to the Board for approval and authorization to execute the amended State Standard Agreement 20-ESGCV1-00008 with HCD. The Agreement contains an indemnification provision that differs from the County standard indemnification provision. CEO Risk Management has reviewed and approved this provision

HCA will submit contracts with selected sub-recipients for the ESG-CV Program funding to the Board for approval once final allocations and award have been received and approved.

Board Resolution Required?
(Please attach document to eForm)

Deputy County Counsel Name:
(Please list the Deputy County Counsel that approved the Resolution)

Yes No

Recommended Action/Special Instructions
(Please specify below)

1. Authorize the Health Care Agency to receive the grant award from the State of California Department of Housing and Community Development for the Emergency Solutions Grants Program CARES Act funds (ESG-CV2) in the amount of \$18,207,901.
2. Authorize the Health Care Agency Director or designee to execute the ESG-CV Standard Agreement and any subsequent amendments or modifications thereto, as well as any other documents which are related to the Emergency Solutions Grants Program or the ESC-CV grant award.

Department Contact :

List the name and contact information (telephone, e-mail) of the staff person to be contacted for further information.

Jason Austin, Director
HCA Office of Care Coordination
jaustin@ochca.com
(714) 834-5000

Name of the individual attending the Board Meeting:

List the name of the individual who will be attending the Board Meeting for this Grant Item:

Jason Austin, Director
HCA Office of Care Coordination



GRANT APPLICATION / GRANT AWARD

Today's Date:	4/5/2021
Requesting Agency/Department:	Health Care Agency / Office of Population Health and Equity
Grant Name and Project Title:	Grant Name: HHS Advancing Health Literacy to Engage Equitable Community Responses to COVID-19, Opportunity No. MP-CPI-21-006 Project Title: OC Building Health Literacy Capacity Initiative
Sponsoring Organization/Grant Source: <small>(If the grant source is not a government entity, please provide a brief description of the organization/foundation)</small>	Department of Health and Human Services Office of the Assistant Secretary for Health
Application Amount Requested:	\$4 million dollars for year period, anticipated start date July 1, 2021
Application Due Date:	April 20, 2021
Board Date when Board Approved this Application:	April 13, 2021
Awarded Funding Amount:	up to 2 million per year for 2 years
Notification Date of Funding Award:	N/A
Is this an Authorized Retroactive Grant Application/Award? No <small>(If yes, attach memo to CEO)</small>	
Recurrence of Grant	New <input checked="" type="checkbox"/> Recurrent <input type="checkbox"/> Other <input type="checkbox"/> Explain:
If this is a recurring grant, please list the funding amount applied for and awarded in the past:	N/A
Does this grant require CEQA findings?	Yes <input type="checkbox"/> No <input checked="" type="checkbox"/>
What Type of Grant is this?	Competitive <input checked="" type="checkbox"/> Other Type <input type="checkbox"/> Explain:
County Match?	Yes <input type="checkbox"/> Amount ____ or ____ % No <input checked="" type="checkbox"/>
How will the County Match be Fulfilled? <small>(Please include the specific budget)</small>	N/A
Will the grant/program create new part or full-time positions?	No
Purpose of Grant Funds:	Provide a summary and brief background of why Board of Supervisors why should accept this grant application/award, and how the grant will be implemented.
<p>The COVID-19 pandemic has revealed disparities in vulnerability to infection, hospitalization, and mortality related to pre-existing disparities. These conditions compounded during the pandemic among racial and ethnic minority groups as well as other underserved populations. One strategy to mitigate health disparities is a comprehensive health literacy initiative that is culturally and linguistically responsive to address these inequities.</p> <p>A targeted and comprehensive strategy for culturally appropriate and responsive health literacy interventions into disproportionately impacted neighborhoods will produce better health outcomes including reducing infection, hospitalization and deaths stemming from exposure to</p>	



**CEO-Legislative Affairs Office
Grant Authorization eForm**

COVID-19. The initiative's primary focus is on Latinx individuals ages 50 years and older; living with chronic medical conditions such as obesity and diabetes; living in linguistically isolated areas of OC including Santa Ana, Anaheim, and Garden Grove; and individuals living in overcrowded housing.

Board Resolution Required?
(Please attach document to eForm)

Deputy County Counsel Name:
(Please list the Deputy County Counsel that approved the Resolution)

Yes No

Recommended Action/Special Instructions
(Please specify below)

The Health Care Agency (HCA) requests that the Board of Supervisors approve the Recommended Action authorizing the Agency to apply for this grant award and delegate authority to the HCA director, or designee, to execute any forms needed in the application process. HCA will return to the Board to obtain approval to accept the awarded funds.

Department Contact :

List the name and contact information (telephone, e-mail) of the staff person to be contacted for further information.

Hieu Nguyen
hnguyen@ochca.com
714-834-2367

Name of the individual attending the Board Meeting:

List the name of the individual who will be attending the Board Meeting for this Grant Item:

Dr. Clayton Chau



**CEO-Legislative Affairs Office
Grant Authorization eForm**

GRANT APPLICATION / **GRANT AWARD**

Today's Date:	March 15, 2021	
Requesting Agency/Department:	Health Care Agency/Health Promotion and Community Planning	
Grant Name and Project Title:	Children's Dental Disease Prevention Program/Local Oral Health Program (LOHP)	
Sponsoring Organization/Grant Source: <small>(If the grant source is not a government entity, please provide a brief description of the organization/foundation)</small>	California Department of Public Health/Office of Oral Health	
Application Amount Requested:	\$100,000	
Application Due Date:	April 21, 2021	
Board Date when Board Approved this Application:	N/A	
Awarded Funding Amount:	Unknown	
Notification Date of Funding Award:	N/A	
Is this an Authorized Retroactive Grant Application/Award? No <small>(If yes, attach memo to CEO)</small>		
Recurrence of Grant	New <input type="checkbox"/> Recurrent <input type="checkbox"/>	Other <input checked="" type="checkbox"/> Explain: One-time funding will be added to current LOHP funding
If this is a recurring grant, please list the funding amount applied for and awarded in the past:	This applicant would result in a one-time funding amendment to the current LOHP grant five-year allocation of \$3,749,050.	
Does this grant require CEQA findings?	Yes <input type="checkbox"/>	No <input checked="" type="checkbox"/>
What Type of Grant is this?	Competitive <input type="checkbox"/>	Other Type <input checked="" type="checkbox"/> Explain: Allocation
County Match?	Yes <input type="checkbox"/> Amount ____ or ____ %	No <input checked="" type="checkbox"/>
How will the County Match be Fulfilled? <small>(Please include the specific budget)</small>	N/A	
Will the grant/program create new part or full-time positions?	No	
Purpose of Grant Funds:	Provide a summary and brief background of why Board of Supervisors why should accept this grant application/award, and how the grant will be implemented.	
This funding allows local health jurisdictions to expand implementation of the local and California Oral Health plans. Utilizing Prop 56 funding, this funding is intended 1)implement a robust community-clinical linkage system using a referral management electronic platform for connecting with parents and linking children to a source of dental care, tracking the progress of care from referral to completion of treatment plan and 2)increase access for children to receive dental sealants and other evidence-based preventive services by creating or expanding school dental programs to reduce the burden of oral diseases.		
Board Resolution Required? <small>(Please attach document to eForm)</small>	Yes <input type="checkbox"/> See attached	No <input checked="" type="checkbox"/>
Deputy County Counsel Name: <small>(Please list the Deputy County Counsel that approved the Resolution)</small>		
Recommended Action/Special Instructions		



**CEO-Legislative Affairs Office
Grant Authorization eForm**

(Please specify below)	
The Health Care Agency requests that the Board of Supervisors approve the Recommended Action authorizing the Agency to apply for this grant for the term of September 1, 2021 through June 30, 2022, and delegate authority to the HCA director, or designee, to execute any forms needed in the application process. HCA will return to the Board to obtain approval to accept the awarded funds.	
Department Contact:	List the name and contact information (telephone, e-mail) of the staff person to be contacted for further information.
Marc Meulman, (714) 834-2980, mmeulman@ochca.com	
Name of the individual attending the Board Meeting:	List the name of the individual who will be attending the Board Meeting for this Grant Item:
Margaret Bredehoft	



**CEO-Legislative Affairs Office
Grant Authorization eForm**

Attachment A

GRANT APPLICATION / GRANT AWARD

Today's Date:	April 5, 2021
Requesting Agency/Department:	Health Care Agency
Grant Name and Project Title:	HIV Emergency Relief Project Grants - Ryan White Part A
Sponsoring Organization/Grant Source: <small>(If the grant source is not a government entity, please provide a brief description of the organization/foundation)</small>	Health Resources Services Administration
Application Amount Requested:	\$6,666,791
Application Due Date:	October 7, 2020
Board Date when Board Approved this Application:	July 28, 2020 (Continuing Grant Matrix)
Awarded Funding Amount:	\$6,292,035
Notification Date of Funding Award:	March 30, 2021
Is this an Authorized Retroactive Grant Application/Award? No <small>(If yes, attach memo to CEO)</small>	
Recurrence of Grant	New <input type="checkbox"/> Recurrent <input checked="" type="checkbox"/> Other <input type="checkbox"/> Explain:
If this is a recurring grant, please list the funding amount applied for and awarded in the past:	The amount applied for in FY 20-21 was \$6,720,056. The FY 20-21 award received was \$6,349,712.
Does this grant require CEQA findings?	Yes <input type="checkbox"/> No <input checked="" type="checkbox"/>
What Type of Grant is this?	Competitive <input checked="" type="checkbox"/> Other Type <input type="checkbox"/> Explain:
County Match?	Yes <input checked="" type="checkbox"/> Amount \$425,000 No <input type="checkbox"/>
How will the County Match be Fulfilled? <small>(Please include the specific budget)</small>	Maintenance of Effort is fulfilled based on unallowable expenses (e.g., salary rate limitations) and unclaimed indirect expenses for the following service categories: Outpatient/Ambulatory Health Services, Medical Nutrition Therapy, Medical Case Management, Early Intervention Services, Case Management: Non-Medical, Medical Transportation and Outreach Services. Funds will be fulfilled through County general funds.
Will the grant/program create new part or full-time positions?	No
Purpose of Grant Funds:	Provide a summary and brief background of why Board of Supervisors why should accept this grant application/award, and how the grant will be implemented.
The HIV Emergency Relief Project Grants - Ryan White Part A program provides funding for HIV care and support services to eligible individuals for early detection of HIV, rapid linkage to medical care, ultimately resulting in HIV viral load suppression and reduced HIV transmission.	
Board Resolution Required? <small>(Please attach document to eForm)</small>	Yes <input type="checkbox"/> No <input checked="" type="checkbox"/>
Deputy County Counsel Name: <small>(Please list the Deputy County Counsel that approved the Resolution)</small>	
Recommended Action/Special Instructions <small>(Please specify below)</small>	
The Health Care Agency (HCA) requests that the Board of Supervisors approve the HIV Emergency Relief Project Grants Ryan White Part A and authorize the Agency to accept awarded funds for the term of March 1, 2021 through February 28, 2022.	



CEO-Legislative Affairs Office Grant Authorization eForm

Attachment A

Authorize the Health Care Agency Director, or designee, to execute such future amendments to this Notice of Award and any other necessary forms needed for this grant referenced above that do not change the Award amount by more than 10% of the original amount and/or make immaterial changes to the scope of work.	
Department Contact :	List the name and contact information (telephone, e-mail) of the staff person to be contacted for further information.
Marc Meulman, (714) 834-2980, mmeulman@ochca.com	
Name of the individual attending the Board Meeting:	List the name of the individual who will be attending the Board Meeting for this Grant Item:
Margaret Bredehoft	
MBredehoft@ochca.com	



**CEO-Legislative Affairs Office
Grant Authorization eForm**

GRANT APPLICATION / **GRANT AWARD**

Today's Date:	March 26, 2021	
Requesting Agency/Department:	Sheriff-Coroner Department	
Grant Name and Project Title:	Tobacco Grant Program	
Sponsoring Organization/Grant Source: <small>(If the grant source is not a government entity, please provide a brief description of the organization/foundation)</small>	Office of the Attorney General, California Department of Justice	
Application Amount Requested:	\$800,000	
Application Due Date:	April 14, 2021	
Board Date when Board Approved this Application:	April 13, 2021	
Awarded Funding Amount:	Pending	
Notification Date of Funding Award:	Pending	
Is this an Authorized Retroactive Grant Application/Award? No <small>(If yes, attach memo to CEO)</small>		
Recurrence of Grant	New <input type="checkbox"/>	Recurrent <input checked="" type="checkbox"/> Other <input type="checkbox"/> Explain:
If this is a recurring grant, please list the funding amount applied for and awarded in the past:	The Sheriff-Coroner Department was awarded \$999,895 for FY 2018.	
Does this grant require CEQA findings?	No <input checked="" type="checkbox"/>	
What Type of Grant is this?	Competitive <input checked="" type="checkbox"/>	Other Type <input type="checkbox"/> Explain: Formula program
County Match?	Yes <input type="checkbox"/> Amount ____ or ____ %	No <input checked="" type="checkbox"/>
How will the County Match be Fulfilled? <small>(Please include the specific budget)</small>	N/A	
Will the grant/program create new part or full-time positions?	No	
Purpose of Grant Funds:	Provide a summary and brief background of why Board of Supervisors why should accept this grant application/award, and how the grant will be implemented.	
<p>Proposition 56 was approved by voters in 2016 to increase taxes on cigarettes and other tobacco products by \$2.00 starting in April 2017. The initiative specifically allocates \$26.8 million of annual revenue to the California Department of Justice to support local law enforcement investigations intended to reduce the illegal sale of tobacco products to minors. Grantees may use grant funds to enforce state and local laws related to the illegal sale and marketing of tobacco products to minors and youth. The purpose of the grant is to enable local law enforcement agencies to expand their efforts in addressing tobacco-related problems, emphasizing enforcement efforts towards the illegal sales of tobacco products to minors and marketing of tobacco products to minors. If awarded, the Sheriff-Coroner Department (Sheriff) will use the grant funding to reduce specific crimes related to the sale of tobacco products to minors through the use of undercover operations. Under California law, "tobacco products" also includes electronic cigarettes (vape pens), flavored tobacco, cigars and cigarillos. This program model provides education as a component for compliance.</p> <p>Selected public agencies will be funded for a two-year to three-year grant cycle. Funding amounts will be evaluated based on the submitted grant proposal.</p>		
Board Resolution Required? <small>(Please attach document to eForm)</small>	Yes <input type="checkbox"/>	No <input checked="" type="checkbox"/>
Deputy County Counsel Name:	Nicole Sims, Supervising Deputy County Counsel, reviewed the application packet.	



CEO-Legislative Affairs Office Grant Authorization eForm

Attachment A

(Please list the Deputy County Counsel that approved the Resolution)	
Recommended Action/Special Instructions (Please specify below)	
Applicants selected for funding must provide a resolution of the applicant's governing body authorizing the applicant to enter into a contract with the State and identifying the person authorized to execute the contract for the applicant. The resolution should expressly authorize future amendments, if any, for the purpose of increasing funding provided in the original contract, without an additional resolution from the governing body. Applicants selected for funding will be required to submit an original or a certified copy of the resolution.	
Department Contact :	List the name and contact information (telephone, e-mail) of the staff person to be contacted for further information.
Luis Ramirez Manager Phone: 714.384.6795 Email: luramirez@ocsd.org Financial Administrative Division	
Name of the individual attending the Board Meeting:	List the name of the individual who will be attending the Board Meeting for this Grant Item:
Sgt. Rocky Castellano	



**CEO-Legislative Affairs Office
Grant Authorization eForm**

GRANT APPLICATION / **GRANT AWARD**

Today's Date:	April 1, 2021
Requesting Agency/Department:	Sheriff-Coroner Department
Grant Name and Project Title:	Surrendered and Abandoned Vessel Exchange (SAVE) Grant
Sponsoring Organization/Grant Source: <small>(If the grant source is not a government entity, please provide a brief description of the organization/foundation)</small>	State of California, Division of Boating and Waterways
Application Amount Requested:	\$60,000
Application Due Date:	April 30, 2021
Board Date when Board Approved this Application:	
Awarded Funding Amount:	
Notification Date of Funding Award:	
Is this an Authorized Retroactive Grant Application/Award? No <small>(If yes, attach memo to CEO)</small>	
Recurrence of Grant	New <input type="checkbox"/> Recurrent <input checked="" type="checkbox"/> Other <input type="checkbox"/> Explain:
If this is a recurring grant, please list the funding amount applied for and awarded in the past:	The Sheriff-Coroner Department (Sheriff), Harbor Patrol unit was awarded Vessel Turn-In Program (VTIP) Grant funds and Abandoned Watercraft Abatement Fund Grant funds by the State of California Department of Parks and Recreation, Boating and Waterways Division in 2014, in the amount of \$5,000 and \$25,000, respectively. Now, two grants (VTIP and the Abandoned Watercraft Abatement Fund) have been combined into one (SAVE). Sheriff was awarded \$40,000 in FY 2018-19, and \$50,000 in FY 2020-21.
Does this grant require CEQA findings?	Yes <input type="checkbox"/> No <input checked="" type="checkbox"/>
What Type of Grant is this?	Competitive <input checked="" type="checkbox"/> Other Type <input type="checkbox"/> Explain:
County Match?	Yes <input checked="" type="checkbox"/> 10% or \$ 4,000 (Cash or in-kind) No <input type="checkbox"/>
How will the County Match be Fulfilled? <small>(Please include the specific budget)</small>	The contribution may be rendered in cash or through in-kind contributions. The contributions may include the following: · Personnel hours (verifiable base net hourly rates only) · Excess expenses above and beyond the grant amount (\$50,000) such as storage, removal, etc.
Will the grant/program create new part or full-time positions?	N/A
Purpose of Grant Funds:	Provide a summary and brief background of why Board of Supervisors why should accept this grant application/award, and how the grant will be implemented.



**CEO-Legislative Affairs Office
Grant Authorization eForm**

The Surrendered and Abandoned Vessel Exchange (SAVE) program combines the Abandoned Watercraft Abatement Fund (AWAF) and the Vessel Turn-In Program (VTIP) grants into one. The AWAF and VTIP are grant programs designed to remove, reduce and prevent abandoned recreational vessels and marine debris. Administered by the California State Parks Division of Boating and Waterways, grants are awarded annually to qualified public agencies statewide. The AWAF and VTIP, enacted in 1998 and 2010 respectively, have provided millions of dollars in grants statewide, and have enabled the removal of thousands of vessels and marine debris.

The proactive VTIP grant was created as a solution to prevent abandoned vessels before they happen. By providing an easy and free alternative for boat owners to surrender an unwanted vessel to a participating agency in lieu of abandonment, this program eliminates the expensive, difficult and time consuming adjudication and removal process that abandoned vessels often require. The VTIP also works to safeguard public and boater safety by preventing the risk of harmful water hazards, and provides for the protection of the environment by preventing discharges of oils, gas, sewage and other toxic pollutants that may leak from an abandoned vessel into the waterways and fragile habitats.

The City of Newport has been covering the cost of abandoned vessels, but has recently taken on more responsibility. With that, the City of Newport requires more of its available funding to cover its current responsibilities and that the County will need funding to cover the cost of removing some of the abandoned vessels. The \$50,000, in SAVE grant funding from the Division of Boating and Waterways will cover the County's cost for removing abandoned vessels. An in-kind or cash match of 10% is required for this grant. The Sheriff-Coroner Department (Sheriff) plans to use 060 funding and/or in-kind activities for the required match. Successful applicants will be funded for a two-year cycle, with the first year commencing October 1, 2021, and ending on September 30, 2023. There will be no change in net General Fund cost and no additional staff. If the application is approved, Sheriff will submit the request for approval through the Board of Supervisors as a resolution is required by the funder to accept the funding.

Board Resolution Required?

(Please attach document to eForm)

Yes

No

Deputy County Counsel Name:

(Please list the Deputy County Counsel that approved the Resolution)

If the application is approved, the Sheriff will return to the Board of Supervisors for approval of a grant resolution addressing the requirements of the grant.

Recommended Action/Special Instructions

(Please specify below)

Authorize the Sheriff-Coroner, or designee, to sign all necessary application documents required for the submission of the application and supporting documentation to the Division of Boating and Waterways.

Nicole Sims, Supervising Deputy County Counsel, has reviewed and approved the application.

Department Contact :

List the name and contact information (telephone, e-mail) of the staff person to be contacted for further information.

Luis Ramirez 714-834-6795
LURAMIREZ@OCSD.ORG

Name of the individual attending the Board Meeting:

List the name of the individual who will be attending the Board Meeting for this Grant Item:

Deputy Diamond Tann



**CEO-Legislative Affairs Office
Grant Authorization eForm**

GRANT APPLICATION / GRANT AWARD

Today's Date:	April 6, 2021																												
Requesting Agency/Department:	Sheriff-Coroner Department																												
Grant Name and Project Title:	State Criminal Alien Assistance Program																												
Sponsoring Organization/Grant Source: <small>(If the grant source is not a government entity, please provide a brief description of the organization/foundation)</small>	Bureau of Justice Assistance/Office of Justice Systems/U.S. Department of Justice																												
Application Amount Requested:	Approximately \$2.5 million (Formula Grant)																												
Application Due Date:	April 19, 2021																												
Board Date when Board Approved this Application:																													
Awarded Funding Amount:																													
Notification Date of Funding Award:																													
Is this an Authorized Retroactive Grant Application/Award? No <small>(If yes, attach memo to CEO)</small>																													
Recurrence of Grant	New <input type="checkbox"/> Recurrent <input checked="" type="checkbox"/> Other <input type="checkbox"/> Explain:																												
If this is a recurring grant, please list the funding amount applied for and awarded in the past:	<table border="1"> <thead> <tr> <th><u>Fiscal Year</u></th> <th><u>Amount Received</u></th> </tr> </thead> <tbody> <tr><td>2007-08</td><td>\$8,368,630</td></tr> <tr><td>2008-09</td><td>\$6,365,293</td></tr> <tr><td>2009-10</td><td>\$6,613,562</td></tr> <tr><td>2010-11</td><td>\$5,287,229</td></tr> <tr><td>2011-12</td><td>\$3,434,999</td></tr> <tr><td>2012-13</td><td>\$2,376,992</td></tr> <tr><td>2013-14</td><td>\$2,330,454</td></tr> <tr><td>2014-15</td><td>\$1,633,416</td></tr> <tr><td>2015-16</td><td>\$1,416,875</td></tr> <tr><td>2016-17</td><td>\$1,491,157</td></tr> <tr><td>2017-18</td><td>\$2,493,792</td></tr> <tr><td>2018-19</td><td>\$2,509,785</td></tr> <tr><td>2019-20</td><td>\$2,465,578</td></tr> </tbody> </table>	<u>Fiscal Year</u>	<u>Amount Received</u>	2007-08	\$8,368,630	2008-09	\$6,365,293	2009-10	\$6,613,562	2010-11	\$5,287,229	2011-12	\$3,434,999	2012-13	\$2,376,992	2013-14	\$2,330,454	2014-15	\$1,633,416	2015-16	\$1,416,875	2016-17	\$1,491,157	2017-18	\$2,493,792	2018-19	\$2,509,785	2019-20	\$2,465,578
	<u>Fiscal Year</u>	<u>Amount Received</u>																											
	2007-08	\$8,368,630																											
	2008-09	\$6,365,293																											
	2009-10	\$6,613,562																											
	2010-11	\$5,287,229																											
	2011-12	\$3,434,999																											
	2012-13	\$2,376,992																											
	2013-14	\$2,330,454																											
	2014-15	\$1,633,416																											
	2015-16	\$1,416,875																											
	2016-17	\$1,491,157																											
	2017-18	\$2,493,792																											
2018-19	\$2,509,785																												
2019-20	\$2,465,578																												
*See explanation under "Purpose of Grant Funds" section.																													
Does this grant require CEQA findings?	Yes <input type="checkbox"/> No <input checked="" type="checkbox"/>																												
What Type of Grant is this?	Competitive <input type="checkbox"/> Other Type <input checked="" type="checkbox"/> Explain: Formula Program																												
County Match?	Yes <input type="checkbox"/> Amount _____ or _____ % No <input checked="" type="checkbox"/>																												
How will the County Match be Fulfilled? <small>(Please include the specific budget)</small>	N/A																												
Will the grant/program create new part or full-time positions?	No																												
Purpose of Grant Funds:	Provide a summary and brief background on why the Board of Supervisors should accept this grant application/award, and how the grant will be implemented.																												
The Office of Justice Systems/U.S. Department of Justice, administered through the Bureau of Justice Assistance (BJA), offers the State Criminal Alien Assistance Program (SCAAP) Grant offering payment to eligible states and units of local government that incur certain types of costs due to incarceration of undocumented criminal aliens during a particular 12-month reporting period. The FY 2020 is authorized																													



**CEO-Legislative Affairs Office
Grant Authorization eForm**

by 8 U.S.C., Section 1231(i) and the Department of Justice Appropriations Action, 2019 (Public Law 116-6) and 28 U.S.C., Section 530(a).

When available, the Sheriff-Coroner Department (Sheriff) applies for SCAAP Grant funding. See Recurring Grant section above for the amounts received in the past.

On April 17, 2007, the Board of Supervisors (Board) approved a Board policy that the Board must approve all grant applications prior to submission to the grantor. The staff responsible for submitting the request to BJA did not view the submission as a grant as Sheriff does not request an amount when the request is submitted, as the SCAAP reimbursement is formula driven. Awards are based on the number of inmates who have served at least four consecutive days and the availability of federal funding each year. The reporting period of FY 2020 SCAAP application is based on actual FY 2018-19 information. The amount received as noted on the table above each fiscal year are for the application submitted for the prior two fiscal years. The amount of revenue the Sheriff received in FY 2019-20 was \$2,465,578 which is for FY 2017-18 services and in FY 2018-19 revenue received was \$2,509,785 which is for services in FY 2016-17.

If awarded, Sheriff intends to utilize the SCAAP funding to cover salaries and wages paid to employees who work primarily and directly in jails; costs related to employment benefits for employees who work directly in and for the jails; and a reasonable allocable portion of the salaries, wages and benefits paid to employees who, although not primarily and directly working in and for the jails and provide necessary services (e.g. salaries and employee benefits of transportation staff, etc.). The intended use for the FY 2020 SCAAP funding is consistent with prior years and used for jail salaries and benefits.

Sheriff plans to return to the Board with a request to accept funding, if the grant for FY 2020 is accepted.

Board Resolution Required?

(Please attach document to eForm)

Yes

No

Deputy County Counsel Name:

(Please list the Deputy County Counsel that approved the Resolution)

Nicole Sims, Supervising Deputy County Counsel, has reviewed and approved the grant application.

Recommended Action/Special Instructions

(Please specify below)

1. Authorize the Sheriff-Coroner or Designee to apply for the SCAAP Grant.
2. Resolution is not required for this grant.

Department Contact :

List the name and contact information (telephone, e-mail) of the staff person to be contacted for further information.

Director Noma M. Crook
Financial/Administrative Services Division
714.834.6681 NCrook@OCSD.org

Name of the individual attending the Board Meeting:

List the name of the individual who will be attending the Board Meeting for this Grant Item:

Lynn Wilkerson, Budget Officer



**CEO-Legislative Affairs Office
Grant Authorization eForm**

Attachment A

GRANT APPLICATION / GRANT AWARD

Today's Date:	April 7, 2021		
Requesting Agency/Department:	Orange County Sheriff-Coroner Department		
Grant Name and Project Title:	Paul Coverdell Forensic Science Improvement Grants Program – Formula Grant		
Sponsoring Organization/Grant Source: <small>(If the grant source is not a government entity, please provide a brief description of the organization/foundation)</small>	U.S. Department of Justice, Office of Justice Programs, and National Institute of Justice		
Application Amount Requested:	\$95,746		
Application Due Date:	December 7, 2020		
Board Date when Board Approved this Application:	May 5, 2020		
Awarded Funding Amount:	\$95,746		
Notification Date of Funding Award:	March 30, 2021		
Is this an Authorized Retroactive Grant Application/Award? <small>(If yes, attach memo to CEO)</small>			
Recurrence of Grant	New <input type="checkbox"/> Recurrent <input checked="" type="checkbox"/> Other <input type="checkbox"/> Explain:		
If this is a recurring grant, please list the funding amount applied for and awarded in the past:	Year	Amount	Purpose
	2015	\$68,000	Purchased a shoeprint GLScan imaging system
	2016	\$75,000	Purchased a nitrogen gas delivery system
	2017	\$74,264	Funded overtime hours for forensic scientists to perform controlled substance and firearms analysis and crime scene investigation report writing
	2018	\$123,284	Funded overtime hours for forensic scientists to perform controlled substance and firearms analysis and crime scene investigation report writing
	2019	\$112,817	Fund the purchase of instrumentation to be used for forensic analysis to replace outdated equipment and to continue to reduce backlog
	2020	\$95,746	Fund the purchase of instrumentation to be used for forensic analysis to replace outdated equipment and to continue to reduce backlog
	Does this grant require CEQA findings?	Yes <input type="checkbox"/> No <input checked="" type="checkbox"/>	



**CEO-Legislative Affairs Office
Grant Authorization eForm**

What Type of Grant is this?	Competitive <input type="checkbox"/>	Other Type: <input checked="" type="checkbox"/> Explain: Crime Labs in California allocation
County Match?	Yes <input type="checkbox"/> Amount _____ or _____ %	No <input checked="" type="checkbox"/>
How will the County Match be Fulfilled? <small>(Please include the specific budget)</small>	N/A	
Will the grant/program create new part or full-time positions?	No	
Purpose of Grant Funds:	Provide a summary and brief background on why the Board of Supervisors should accept this grant application/award, and how the grant will be implemented.	
<p>The Paul Coverdell Forensic Science Improvement Grants Program awards funds to help improve the quality and timeliness of forensic science services. Funds are awarded to accredited law enforcement laboratories based on the number of managers, forensic scientists, forensic specialists and technicians in the laboratory. The performance period for this grant is January 1, 2021 to December 31, 2021. Grant funds are intended to be used to fund the purchase of instrumentation to be used for forensic analysis to replace outdated equipment and to continue to reduce backlog.</p> <p>The Paul Coverdell Forensic Science Improvement Grants Program awards 2020 funds in 2021. An electronic notification of the 2020 award was received on March 30, 2021.</p>		
Board Resolution Required? <small>(Please attach document to eForm)</small> Deputy County Counsel Name: <small>(Please list the Deputy County Counsel that approved the Resolution)</small>	Yes <input type="checkbox"/> No <input checked="" type="checkbox"/> N/A; Nicole Sims, Supervising Deputy County Counsel, reviewed the application packet.	
Recommended Action/Special Instructions <small>(Please specify below)</small>		
Request approval to accept Paul Coverdell Forensic Science Improvement Grants Program funding.		
Department Contact :	List the name and contact information (telephone, e-mail) of the staff person to be contacted for further information.	
Bruce Houlihan, Director Orange County Crime Laboratory, 714-834-4510, bruceh@occl.ocgov.com		
Name of the individual attending the Board Meeting:	List the name of the individual who will be attending the Board Meeting for this Grant Item:	
Joseph Jaing, Assistant Director Orange County Crime Laboratory, 714-834-4510 JTJ@occl.ocgov.com		



Continuation or Deletion Request

Date: April 6, 2021
To: Clerk of the Board of Supervisors
From: Frank Kim, County Executive Officer
Re: ASR Control #: 20-001239, Meeting Date 4/13/21 Agenda Item No. # 45
Subject: Abandonment and Conveyance of Property in Upper Newport Bay

Request to continue Agenda Item No. # 45 to the 05/11/21 Board Meeting.

Comments:

Request deletion of Agenda Item No. # _____

Comments:



PROCESSED BY:

M

RECEIVED
CLERK OF THE BOARD

APR 06 2021

MEMORANDUM

To: Robin Stieler, Clerk of the Board

From: Chairman Andrew Do, Supervisor, 1st District

For A.D.

Date: 04/06/21

RE: Supplemental Item for April 13, 2021 Agenda

#S43A

Please add this memo and attachment as a Supplemental Item to the April 13, 2021 Board of Supervisors meeting agenda:

Subject: Additional 2021 Chairman Appointments

Recommended Action: Approve the Chairman's additional 2021 appointments to Boards, Commissions, and Committees as presented in Attachment A.

cc: Chris Wangsaporn, Chief of Staff, BOS-1
Valerie Sanchez, Chief Deputy Clerk, COB



**SUPPLEMENTAL AGENDA ITEM
 AGENDA STAFF REPORT**

RECEIVED
 CLERK OF THE BOARD

APR 06 2021

MEETING DATE: 04/13/2021
LEGAL ENTITY TAKING ACTION: Board of Supervisors
BOARD OF SUPERVISORS DISTRICT(S): All Districts
SUBMITTING AGENCY/DEPARTMENT: Clerk of the Board
DEPARTMENT HEAD REVIEW: Robin Stieler
Department Head Signature
DEPARTMENT CONTACT PERSON(S): Robin Stieler (714) 834-2206
 Valerie Sanchez (714) 834-2206

SUBJECT: Additional 2021 Chairman Appointments

CEO CONCUR	COUNTY COUNSEL REVIEW	CLERK OF THE BOARD
N/A	N/A Action	Discussion
<hr/>	N/A	3 Votes Board Majority
<i>CEO Signature</i>	<i>County Counsel Signature</i>	

Budgeted: N/A **Current Year Cost:** N/A **Annual Cost:** N/A
Staffing Impact: No **# of Positions:** N/A **Sole Source:** N/A
Current Fiscal Year Revenue: N/A
Funding Source: N/A **County Audit in last 3 years** No

Prior Board Action: 01/26/2021, #S30E

RECOMMENDED ACTION(S)

1. Approve 2021 Chairman's appointments of newly elected 2nd District Supervisor Katrina Foley to various Boards, Commissions, and Committees as highlighted in Attachment A.
2. Adopt revised California Form 806 - Agency Report of Public Official Appointments and direct Clerk of the Board to post on the County's internet website and to update as required by law.

SUMMARY:

Approval of 2021 Chairman's appointments of newly elected 2nd District Supervisor Katrina Foley to various Boards, Commissions and Committees, including adoption of the revised California Form 806 - Agency Report of Public Official Appointments, will ensure continued Board of Supervisors representation on various decision making bodies and fulfill Fair Political Practices Commission regulations.

BACKGROUND INFORMATION:

On January 26, 2021, Item S30E, the Board of Supervisors (Board) approved the Chairman's appointment of Board members to various Boards, Commissions and Committees (BCC's). The vacancy in District 2 left some appointments vacant until after the special election held on March 9, 2021. Newly elected 2nd District Supervisor Katrina Foley has been sworn into office and may now be appointed to County BCC's.

Additionally, the Fair Political Practices Commission Regulation 18702.5 requires the Board to adopt California Form 806 - Agency Report of Public Official Appointments and to post it on the County's website.

FINANCIAL IMPACT:

N/A

STAFFING IMPACT:

N/A

ATTACHMENT(S):

Attachment A – 2021 Chairman's Appointments

Attachment B – Revised FPPC Form 806

Attachment C – FPPC Regulation 18702.5

ATTACHMENT A

2021 CHAIR APPOINTMENTS

(Term of appointments are 1/1/21 - 12/31/21 unless otherwise noted)

COMMITTEE NAME	POSITION/COMMENTS	2021 APPOINTMENT
California State Association of Counties (CSAC) (Quarterly meetings; day/time varies)	Regular Member Alternate Member	Bartlett Chaffee
CalOptima (Monthly; first Thursday at 2:00 P.M.)	Regular Member Regular Member Alternate Member	Do Chaffee Bartlett
First 5 Orange County, Children & Families Commission (Bi-monthly as needed; first Wednesday at 9:00 A.M.)	Regular Member Alternate Member Nominations for Category 1 (Education) appointments* Nominations for Category 2 (Health) appointments* *The chair appoints 2 Supervisors to these slots as defined by Ord. Sec. 1-2-335 after the Regular Member is determined. These two appointments are not members of the commission, their sole duty is to make nominations to the BOS in April of each year for upcoming commission vacant slots	Chaffee Foley Foley Do
Coastal Greenbelt Authority (Bi-monthly; third Thursday at 5:30 P.M.)	Regular Member (May be a BOS Member or other County official)	Bartlett
Commission to End Homelessness (Bi-monthly; fourth or fifth Friday at 9:00 A.M.)	Regular Member (8/28/18 - 8/28/21) Regular Member (8/29/20 - 8/28/22)	Do Chaffee

ATTACHMENT A

2021 CHAIR APPOINTMENTS

(Term of appointments are 1/1/21 - 12/31/21 unless otherwise noted)

COMMITTEE NAME	POSITION/COMMENTS	2021 APPOINTMENT
Emergency Management Council (Quarterly; day/time varies)	Regular Member Alternate Member #1 Alternate Member #2 Alternate Member #3 Alternate Member #4	Bartlett Chaffee Wagner Do Foley
Law Library Board of Trustees (Monthly; third Tuesday at 12:00 P.M.)	Regular Member #1 (May be BOS member or OC resident) Regular Member #2 (Must be a member of California State Bar)	Sherry L. Leysen Michael Franco
Local Agency Formation Commission (LAFCO) (Monthly; second Wednesday at 8:00 A.M.)	Regular Member - (7/1/18 - 6/30/22)* Regular Member (7/1/19 - 6/30/23)** Alternate Member (7/1/19 - 6/30/23)*** *Provided for information only, this four-year appointment was approved by BOS on 1/23/18 **Provided for information only, this four-year appointment was approved by BOS on 1/29/19 ***Appoint a new alternate member to complete the existing term	Wagner Bartlett Foley
National Association of Counties (NACO) (Biennially; March and July)	Regular Member Alternate Member	Bartlett Chaffee
Newport Bay Watershed Executive Committee (Central (Newport Bay) Watershed Management Area) (Quarterly meetings; day/time varies)	Regular Member Alternate Member	Foley Bartlett

ATTACHMENT A

2021 CHAIR APPOINTMENTS

(Term of appointments are 1/1/21 - 12/31/21 unless otherwise noted)

COMMITTEE NAME	POSITION/COMMENTS	2021 APPOINTMENT
OC Operational Area Executive Board (Quarterly; day/time varies)	Regular Member Alternate Member	Chaffee Bartlett
OC Public Libraries Advisory Board (Thrice per year)	Regular Member Regular Member (Members represent library branches located in unincorporated areas)	Bartlett Wagner
One Water, One Watershed (As needed)	Regular Member (Current term 3/2/21 - 3/1/25)	Chaffee
Orange County Audit Oversight Committee (Quarterly Meetings; day/time varies)	Regular Member (BOS Chair) Regular Member (BOS Vice Chair)	Do Chaffee
Orange County Children's Partnership (Monthly, third Thursday at 8:30 A.M.)	Regular Member	Chaffee
Orange County Community Corrections Partnership (OCCCP) (Quarterly; fourth Thursday at 2:00 P.M.)	Regular Member (Same as BOS Regular Member on OCCJCC) Alternate Member (Same as BOS Alternate Member on OCCJCC)	Chaffee Foley
Orange County Criminal Justice Coordinating Council (OCCJCC) (Monthly; third Friday at 9:30 A.M.)	Regular Member (Same as BOS Regular Member on OCCCP) Alternate Member (Same as BOS Alternate Member on OCCCP)	Do Chaffee
Orange County Fire Authority (OCFA) (Monthly; fourth Thursday at 6:00 P.M.)	Regular Member Regular Member (Note: If these appointments change, a resolution for OCFA will be included with the ASR)	Bartlett Wagner

ATTACHMENT A

2021 CHAIR APPOINTMENTS

(Term of appointments are 1/1/21 - 12/31/21 unless otherwise noted)

COMMITTEE NAME	POSITION/COMMENTS	2021 APPOINTMENT
Orange County Housing Finance Trust (OCHFT) (Bi-Monthly)	Regular Member (5/21/19 - 5/20/21) Regular Member (1/26/21 - 1/25/23) Countywide Elected Official (5/21/19 - 5/20/21) Countywide Elected Official (5/21/19 - 5/20/21) *New 2-year appointments begin date of appointment	Chaffee Bartlett Don Barnes Shari Freidenrich
Orange County Juvenile Justice Coordinating Council (OCJJCC) (Quarterly, fourth Thursday at 3:30 P.M.)	Regular Member Alternate Member	Chaffee Foley
Orange County Local Remote Access Network (RAN) (As needed)	Regular Member Alternate Member (May be a BOS Member or staff representative)	Chaffee Wagner
Orange County Mental Health Board (Bi-monthly; second Tues. at 9:00 A.M.; fourth Wed at 9:00 A.M.)	Regular Member	Foley
Orange County Mosquito and Vector Control District (Monthly; third Thursday at 3:00 P.M.)	Regular Member (1/5/21 - 1/2/23)* (May be BOS or Designee) *Terms end first Monday in January	CEO Designee Elizabeth Guillen-Merchant
Orange County Parks Foundation Annual; third Friday in July at 10:00 A.M.)	County Director (May be a BOS Member or other)	Chaffee

ATTACHMENT A

2021 CHAIR APPOINTMENTS

(Term of appointments are 1/1/21 - 12/31/21 unless otherwise noted)

COMMITTEE NAME	POSITION/COMMENTS	2021 APPOINTMENT
Orange County Sanitation District (Monthly; fourth Wednesday at 6:00 P.M.)	Regular Member Alternate Member	Chaffee Wagner
Orange County Transportation Authority (OCTA) (Bi-monthly; second and fourth Monday at 9:00 A.M.)	Regular Member (1st District BOS Member) Regular Member (2nd District BOS Member) Regular Member (3rd District BOS Member) Regular Member (4th District BOS Member) Regular Member (5th District BOS Member)	Do Foley Wagner Chaffee Bartlett
Santa Ana River Flood Control Protection Agency (Seven per year; days vary; 4:00 P.M.)	BOS Representative OC Flood Control District Representative Alternate BOS Representative (May be BOS or staff designee) Alternate OCFCD Representative (May be BOS or staff designee)	Chaffee Wagner Alkamalee (Al) Jabbar James Tyler
South Coast Air Quality Management District (AQMD) (Monthly; first Friday at 9:00 A.M.)	Regular Member	Bartlett
South Orange County Watershed Management Area Executive Committee (Thrice per year)	Regular Member Alternate Member	Bartlett Foley
Southern California Association of Governments (SCAG) Regional Council and General Assembly (Monthly; first Thursday at 12:15 P.M.)	Official Representative Alternate Representative	Wagner Chaffee

ATTACHMENT A**2021 CHAIR APPOINTMENTS****(Term of appointments are 1/1/21 - 12/31/21 unless otherwise noted)**

COMMITTEE NAME	POSITION/COMMENTS	2021 APPOINTMENT
Southern California Home Financing Authority (SCHFA) (4-5 times per year)	Regular Member (BOS Chair) CEO or Designee Member	Do Frank Kim
Transportation Corridor Agency - Foothill/Eastern (Monthly; second Thursday at 9:30 A.M.)	Regular Member (3rd District BOS Member) Regular Member (4th District BOS Member) Regular Member (5th District BOS Member)	Wagner Chaffee Bartlett
Transportation Corridor Agency - San Joaquin Hills (Monthly; second Thursday at 9:30 A.M.)	Regular Member (3rd District BOS Member) Regular Member (5th District BOS Member)	Wagner Bartlett
Urban Counties Caucus (Monthly; first Wednesday at 4:00 P.M.)	Regular Member Alternate Member	Bartlett Chaffee

Agency Report of:
Public Official Appointments

A Public Document

1. Agency Name County of Orange Division, Department, or Region (If Applicable) Board of Supervisors Designated Agency Contact (Name, Title) Robin Stieler, Clerk of the Board		California Form 806 For Official Use Only
Area Code/Phone Number 714-834-2206	E-mail response@ocgov.com	
Page <u>1</u> of <u>4</u>		Date Posted: _____ (Month, Day, Year)

2. Appointments

Agency Boards and Commissions	Name of Appointed Person	Appt Date and Length of Term	Per Meeting/Annual Salary/Stipend
Children & Families Commission of Orange County	▶ Name <u>Chaffee, Doug</u> <small>(Last, First)</small> Alternate, if any <u>Foley, Katrina</u> <small>(Last, First)</small>	▶ <u>1 / 26 / 21</u> <small>Appt Date</small> ▶ <u>1 Year</u> <small>Length of Term</small>	▶ Per Meeting: \$ <u>100.00</u> ▶ Estimated Annual: <input checked="" type="checkbox"/> \$0-\$1,000 <input type="checkbox"/> \$2,001-\$3,000 <input type="checkbox"/> \$1,001-\$2,000 <input type="checkbox"/> <u>Other</u>
Local Agency Formation Commission (LAFCO)	▶ Name <u>Wagner, Donald</u> <small>(Last, First)</small> Alternate, if any <u>Foley, Katrina</u> <small>(Last, First)</small>	▶ <u>1 / 23 / 18</u> <small>Appt Date</small> ▶ <u>4 Years</u> <small>Length of Term</small>	▶ Per Meeting: \$ <u>100.00</u> ▶ Estimated Annual: <input type="checkbox"/> \$0-\$1,000 <input checked="" type="checkbox"/> \$2,001-\$3,000 <input type="checkbox"/> \$1,001-\$2,000 <input type="checkbox"/> <u>Other</u>
Local Agency Formation Commission (LAFCO)	▶ Name <u>Bartlett, Lisa</u> <small>(Last, First)</small> Alternate, if any <u>Foley, Katrina</u> <small>(Last, First)</small>	▶ <u>1 / 29 / 19</u> <small>Appt Date</small> ▶ <u>4 Years</u> <small>Length of Term</small>	▶ Per Meeting: \$ <u>100.00</u> ▶ Estimated Annual: <input type="checkbox"/> \$0-\$1,000 <input checked="" type="checkbox"/> \$2,001-\$3,000 <input type="checkbox"/> \$1,001-\$2,000 <input type="checkbox"/> <u>Other</u>
Orange County Mental Health Board	▶ Name <u>Foley, Katrina</u> <small>(Last, First)</small> Alternate, if any _____ <small>(Last, First)</small>	▶ <u>4 / 13 / 21</u> <small>Appt Date</small> ▶ <u>1 Year</u> <small>Length of Term</small>	▶ Per Meeting: \$ <u>20.00</u> ▶ Estimated Annual: <input checked="" type="checkbox"/> \$0-\$1,000 <input type="checkbox"/> \$2,001-\$3,000 <input type="checkbox"/> \$1,001-\$2,000 <input type="checkbox"/> <u>Other</u>

3. Verification

I have read and understand FPPC Regulation 18702.5. I have verified that the appointment and information identified above is true to the best of my information and belief.

 _____ Robin Stieler _____ Clerk of the Board _____
Signature of Agency Head or Designee Print Name Title (Month, Day, Year)

Comment: _____

Agency Report of:
Public Official Appointments
Continuation Sheet

1. Agency Name County of Orange	Date Posted: _____ <small>(Month, Day, Year)</small>
---	--

Agency Boards and Commissions	Name of Appointed Person	Appt Date and Length of Term	Per Meeting/Annual Salary/Stipend
Orange County Children's Partnership	▶ Name <u>Chaffee, Doug</u> <small>(Last, First)</small> Alternate, if any <u>None</u> <small>(Last, First)</small>	▶ <u>1 / 26 / 21</u> <small>Appt Date</small> ▶ <u>1 Year</u> <small>Length of Term</small>	▶ Per Meeting: \$ <u>25.00</u> ▶ Estimated Annual: <input checked="" type="checkbox"/> \$0-\$1,000 <input type="checkbox"/> \$2,001-\$3,000 <input type="checkbox"/> \$1,001-\$2,000 <input type="checkbox"/> <u>Other</u>
Orange County Fire Authority	▶ Name <u>Bartlett, Lisa</u> <small>(Last, First)</small> Alternate, if any <u>None</u> <small>(Last, First)</small>	▶ <u>1 / 26 / 21</u> <small>Appt Date</small> ▶ <u>1 Year</u> <small>Length of Term</small>	▶ Per Meeting: \$ <u>100.00</u> ▶ Estimated Annual: <input type="checkbox"/> \$0-\$1,000 <input type="checkbox"/> \$2,001-\$3,000 <input type="checkbox"/> \$1,001-\$2,000 <input checked="" type="checkbox"/> <u>\$3600.00</u> <small>Other</small>
Orange County Fire Authority	▶ Name <u>Wagner, Donald</u> <small>(Last, First)</small> Alternate, if any <u>None</u> <small>(Last, First)</small>	▶ <u>1 / 26 / 21</u> <small>Appt Date</small> ▶ <u>1 Year</u> <small>Length of Term</small>	▶ Per Meeting: \$ <u>100.00</u> ▶ Estimated Annual: <input type="checkbox"/> \$0-\$1,000 <input type="checkbox"/> \$2,001-\$3,000 <input type="checkbox"/> \$1,001-\$2,000 <input checked="" type="checkbox"/> <u>\$3600.00</u> <small>Other</small>
Orange County Sanitation District	▶ Name <u>Chaffee, Doug</u> <small>(Last, First)</small> Alternate, if any <u>Wagner, Donald</u> <small>(Last, First)</small>	▶ <u>1 / 26 / 21</u> <small>Appt Date</small> ▶ <u>1 Year</u> <small>Length of Term</small>	▶ Per Meeting: \$ <u>212.50</u> ▶ Estimated Annual: <input type="checkbox"/> \$0-\$1,000 <input type="checkbox"/> \$2,001-\$3,000 <input type="checkbox"/> \$1,001-\$2,000 <input checked="" type="checkbox"/> <u>\$5100.00</u> <small>Other</small>
Orange County Transportation Authority	▶ Name <u>Do, Andrew</u> <small>(Last, First)</small> Alternate, if any <u>None</u> <small>(Last, First)</small>	▶ <u>1 / 26 / 21</u> <small>Appt Date</small> ▶ <u>1 Year</u> <small>Length of Term</small>	▶ Per Meeting: \$ <u>100.00</u> ▶ Estimated Annual: <input type="checkbox"/> \$0-\$1,000 <input checked="" type="checkbox"/> \$2,001-\$3,000 <input type="checkbox"/> \$1,001-\$2,000 <input type="checkbox"/> <u>Other</u>
Orange County Transportation Authority	▶ Name <u>Foley, Katrina</u> <small>(Last, First)</small> Alternate, if any <u>None</u> <small>(Last, First)</small>	▶ <u>4 / 13 / 21</u> <small>Appt Date</small> ▶ <u>1 Year</u> <small>Length of Term</small>	▶ Per Meeting: \$ <u>100.00</u> ▶ Estimated Annual: <input type="checkbox"/> \$0-\$1,000 <input checked="" type="checkbox"/> \$2,001-\$3,000 <input type="checkbox"/> \$1,001-\$2,000 <input type="checkbox"/> <u>Other</u>

**Agency Report of:
Public Official Appointments
Continuation Sheet**

1. Agency Name County of Orange	Date Posted: _____ <small>(Month, Day, Year)</small>
---	--

Agency Boards and Commissions	Name of Appointed Person	Appt Date and Length of Term	Per Meeting/Annual Salary/Stipend
Orange County Transportation Authority	▶ Name <u>Wagner, Donald</u> <small>(Last, First)</small> Alternate, if any <u>None</u> <small>(Last, First)</small>	▶ <u>1 / 26 / 21</u> <small>Appt Date</small> ▶ <u>1 Year</u> <small>Length of Term</small>	▶ Per Meeting: \$ <u>100.00</u> ▶ Estimated Annual: <input type="checkbox"/> \$0-\$1,000 <input checked="" type="checkbox"/> \$2,001-\$3,000 <input type="checkbox"/> \$1,001-\$2,000 <input type="checkbox"/> <u>Other</u>
Orange County Transportation Authority	▶ Name <u>Chaffee, Doug</u> <small>(Last, First)</small> Alternate, if any <u>None</u> <small>(Last, First)</small>	▶ <u>1 / 26 / 21</u> <small>Appt Date</small> ▶ <u>1 Year</u> <small>Length of Term</small>	▶ Per Meeting: \$ <u>100.00</u> ▶ Estimated Annual: <input type="checkbox"/> \$0-\$1,000 <input checked="" type="checkbox"/> \$2,001-\$3,000 <input type="checkbox"/> \$1,001-\$2,000 <input type="checkbox"/> <u>Other</u>
Orange County Transportation Authority	▶ Name <u>Bartlett, Lisa</u> <small>(Last, First)</small> Alternate, if any <u>None</u> <small>(Last, First)</small>	▶ <u>1 / 26 / 21</u> <small>Appt Date</small> ▶ <u>1 Year</u> <small>Length of Term</small>	▶ Per Meeting: \$ <u>100.00</u> ▶ Estimated Annual: <input type="checkbox"/> \$0-\$1,000 <input checked="" type="checkbox"/> \$2,001-\$3,000 <input type="checkbox"/> \$1,001-\$2,000 <input type="checkbox"/> <u>Other</u>
South Coast Air Quality Management District	▶ Name <u>Bartlett, Lisa</u> <small>(Last, First)</small> Alternate, if any <u>None</u> <small>(Last, First)</small>	▶ <u>1 / 26 / 21</u> <small>Appt Date</small> ▶ <u>1 Year</u> <small>Length of Term</small>	▶ Per Meeting: \$ <u>100.00</u> ▶ Estimated Annual: <input type="checkbox"/> \$0-\$1,000 <input checked="" type="checkbox"/> \$2,001-\$3,000 <input type="checkbox"/> \$1,001-\$2,000 <input type="checkbox"/> <u>Other</u>
Southern California Association of Governments	▶ Name <u>Wagner, Donald</u> <small>(Last, First)</small> Alternate, if any <u>Chaffee, Doug</u> <small>(Last, First)</small>	▶ <u>1 / 26 / 21</u> <small>Appt Date</small> ▶ <u>1 Year</u> <small>Length of Term</small>	▶ Per Meeting: \$ <u>120.00</u> ▶ Estimated Annual: <input type="checkbox"/> \$0-\$1,000 <input type="checkbox"/> \$2,001-\$3,000 <input checked="" type="checkbox"/> \$1,001-\$2,000 <input type="checkbox"/> <u>Other</u>
Transportation Corridor Agency - Foothill/Eastern	▶ Name <u>Wagner, Donald</u> <small>(Last, First)</small> Alternate, if any <u>None</u> <small>(Last, First)</small>	▶ <u>1 / 26 / 21</u> <small>Appt Date</small> ▶ <u>1 Year</u> <small>Length of Term</small>	▶ Per Meeting: \$ <u>120.00</u> ▶ Estimated Annual: <input type="checkbox"/> \$0-\$1,000 <input checked="" type="checkbox"/> \$2,001-\$3,000 <input type="checkbox"/> \$1,001-\$2,000 <input type="checkbox"/> <u>Other</u>

**Agency Report of:
Public Official Appointments
Continuation Sheet**

1. Agency Name
County of Orange

Date Posted: _____
(Month, Day, Year)

Agency Boards and Commissions	Name of Appointed Person	Appt Date and Length of Term	Per Meeting/Annual Salary/Stipend
Transportation Corridor Agency - Foothill/Eastern	▶ Name <u>Chaffee, Doug</u> <i>(Last, First)</i> Alternate, if any <u>None</u> <i>(Last, First)</i>	▶ <u>1 / 26 / 21</u> <i>Appt Date</i> ▶ <u>1 Year</u> <i>Length of Term</i>	▶ Per Meeting: \$ <u>120.00</u> ▶ Estimated Annual: <input type="checkbox"/> \$0-\$1,000 <input checked="" type="checkbox"/> \$2,001-\$3,000 <input type="checkbox"/> \$1,001-\$2,000 <input type="checkbox"/> <u> </u> <i>Other</i>
Transportation Corridor Agency - Foothill/Eastern	▶ Name <u>Bartlett, Lisa</u> <i>(Last, First)</i> Alternate, if any <u>None</u> <i>(Last, First)</i>	▶ <u>1 / 26 / 21</u> <i>Appt Date</i> ▶ <u>1 Year</u> <i>Length of Term</i>	▶ Per Meeting: \$ <u>120.00</u> ▶ Estimated Annual: <input type="checkbox"/> \$0-\$1,000 <input checked="" type="checkbox"/> \$2,001-\$3,000 <input type="checkbox"/> \$1,001-\$2,000 <input type="checkbox"/> <u> </u> <i>Other</i>
Transportation Corridor Agency - San Joaquin Hills	▶ Name <u>Wagner, Donald</u> <i>(Last, First)</i> Alternate, if any <u>None</u> <i>(Last, First)</i>	▶ <u>1 / 26 / 21</u> <i>Appt Date</i> ▶ <u>1 Year</u> <i>Length of Term</i>	▶ Per Meeting: \$ <u>120.00</u> ▶ Estimated Annual: <input type="checkbox"/> \$0-\$1,000 <input checked="" type="checkbox"/> \$2,001-\$3,000 <input type="checkbox"/> \$1,001-\$2,000 <input type="checkbox"/> <u> </u> <i>Other</i>
Transportation Corridor Agency - San Joaquin Hills	▶ Name <u>Bartlett, Lisa</u> <i>(Last, First)</i> Alternate, if any <u>None</u> <i>(Last, First)</i>	▶ <u>1 / 26 / 21</u> <i>Appt Date</i> ▶ <u>1 Year</u> <i>Length of Term</i>	▶ Per Meeting: \$ <u>120.00</u> ▶ Estimated Annual: <input type="checkbox"/> \$0-\$1,000 <input checked="" type="checkbox"/> \$2,001-\$3,000 <input type="checkbox"/> \$1,001-\$2,000 <input type="checkbox"/> <u> </u> <i>Other</i>
	▶ Name _____ <i>(Last, First)</i> Alternate, if any _____ <i>(Last, First)</i>	▶ _____ <i>Appt Date</i> ▶ _____ <i>Length of Term</i>	▶ Per Meeting: \$ _____ ▶ Estimated Annual: <input type="checkbox"/> \$0-\$1,000 <input type="checkbox"/> \$2,001-\$3,000 <input type="checkbox"/> \$1,001-\$2,000 <input type="checkbox"/> _____ <i>Other</i>
	▶ Name _____ <i>(Last, First)</i> Alternate, if any _____ <i>(Last, First)</i>	▶ _____ <i>Appt Date</i> ▶ _____ <i>Length of Term</i>	▶ Per Meeting: \$ _____ ▶ Estimated Annual: <input type="checkbox"/> \$0-\$1,000 <input type="checkbox"/> \$2,001-\$3,000 <input type="checkbox"/> \$1,001-\$2,000 <input type="checkbox"/> _____ <i>Other</i>

(Regulations of the Fair Political Practices Commission, Title 2, Division 6, California Code of Regulations.)

§ 18702.5. Materiality Standard: Financial Interest in a Personal Financial Effect.

(a) A personal financial effect means the financial effect of a governmental decision on the personal finances of a public official or his or her immediate family. The financial effect is material if the official or the official's immediate family member will receive a measurable financial benefit or loss from the decision.

(b) Notwithstanding subdivision (a), a personal financial effect does not include:

(1) Any establishment of or change to benefits provided under an employment or retirement policy for employees or retirees if the financial effect of the decision applies equally to all employees in the same bargaining unit or other representative group.

(2) Payment of any travel expenses, to the extent allowed by law, incurred while attending meetings as an authorized representative of an agency.

(3) Stipends received for attendance at meetings of any group or body created by law or formed by the official's agency for a special purpose, so long as the selecting body posts on its website a form provided by the Commission that includes: a list of each appointed position eligible for a stipend, the amount of the stipend for each position, the name of the public official who has been appointed to the position, the name of the public official, if any, who has been appointed as an alternate, and the term of the position.

(4) The use of any government property, such as automobiles or other modes of transportation, mobile communication devices, or other agency provided equipment for carrying out the official duties of a position, including any nominal, incidental, negligible, or inconsequential personal use while on duty.

(5) Any personal reward received by the official when using a personal charge card or membership rewards program, so long as the reward is no different from the reward offered to the public and is limited to charges made solely for the official's approved travel expenses.

(6) A decision to fill a position on the body of which the official is a member.

(c) If the governmental decision affects a business entity or real property in which the official has a financial interest, this regulation does not apply and materiality is determined under Regulation 18702.1 or 18702.2.

Note: Authority cited: Section 83112, Government Code. Reference: Sections 87100, 87102.5, 87102.6, 87102.8 and 87103, Government Code.

HISTORY

1. New section filed 6-10-2003; operative 6-10-2003 (Register 2003, No. 24). For prior history, see Register 98, No. 48.

2. Amendment of subsection (b)(1)(A) filed 10-26-2004; operative 11-25-2004 (Register 2004, No. 44).

3. Change without regulatory effect renumbering former section 18702.5 to section 18704.5 and renumbering former section 18705.5 to section 18702.5, including amendment of subsection (c), filed 4-27-2015. Submitted to OAL for filing pursuant to *Fair Political Practices Commission v. Office of Administrative Law*, 3 Civil C010924, California Court of Appeal, Third Appellate District, nonpublished decision, April 27, 1992 (FPPC regulations only subject to 1974 Administrative Procedure Act rulemaking requirements and not subject to procedural or substantive review by OAL) (Register 2015, No. 18).



543B

MEMORANDUM

To: Clerk of the Board

From: Katrina Foley 

Date: April 7, 2021

RE: Appointment of Alexander Gonzalez to the Orange County Veterans Advisory Council

I would like to appoint Alexander Gonzalez to the Orange County Veterans Advisory Council.

Please place this item on the 4/13/21 agenda.

RECEIVED
CLERK OF THE BOARD

APR 07 2021



APPLICATION FOR COUNTY OF ORANGE BOARD, COMMISSION OR COMMITTEE

(FOR COUNTY USE ONLY)

Return to:
Clerk of the Board of Supervisors
333 West Santa Ana Blvd., Suite 465
Santa Ana, California 92701
Website: www.ocgov.com/gov/cob/

Instructions: Please complete each section below. Be sure to enter the title of the Board, Commission or Committee for which you desire consideration. For information or assistance, please contact the Clerk of the Board of Supervisor's Office at (714) 834-2206. Please print in ink or type.

NAME OF BOARD, COMMISSION, OR COMMITTEE TO WHICH YOU ARE APPLYING FOR MEMBERSHIP (SEE LIST AT HTTP://WWW.OCGOV.COM/GOV/COB/BCC/CONTACT):

SUPERVISORIAL DISTRICT IN WHICH YOU RESIDE: [] First [X] Second [] Third [] Fourth [] Fifth

APPLICANT NAME AND RESIDENCE ADDRESS:

Alexander Christopher Gonzalez
First Name Middle Name Last Name

Home Phone Number Cell Phone Number

Email Address

CURRENT EMPLOYER:

OCCUPATION/JOB TITLE:

BUSINESS ADDRESS:

BUSINESS PHONE NUMBER:

EMPLOYMENT HISTORY: Please attach a resume to this application and provide any information that would be helpful in evaluating your application.

ARE YOU A CITIZEN OF THE UNITED STATES: [X] YES [] NO

IF NO, NAME OF COUNTRY OF CITIZENSHIP:

ARE YOU A REGISTERED VOTER? [X] YES [] NO

IF YES, NAME COUNTY YOU ARE REGISTERED IN:

LIST ALL CURRENT PROFESSIONAL OR COMMUNITY ORGANIZATIONS AND SOCIETIES OF WHICH YOU ARE A MEMBER.

ORGANIZATION/SOCIETY	FROM (MO./YR.)	TO (MO./YR.)
Veterans & Foreign Wars	2017 - Present	
American Legion	2020	Present

WITHIN THE LAST FIVE YEARS, HAVE YOU BEEN AFFILIATED WITH ANY BUSINESS OR NONPROFIT AGENCY(IES)? YES NO

DO YOU OWN REAL OR PERSONAL PROPERTY OR HAVE FINANCIAL HOLDING WHICH MIGHT PRESENT A POTENTIAL CONFLICT OF INTEREST? YES NO

HAVE YOU BEEN CONVICTED OF A FELONY OR MISDEMEANOR CRIME SINCE YOUR 18TH BIRTHDAY? YOU ARE NOT REQUIRED TO DISCLOSE ANY OF THE FOLLOWING: ARRESTS OR DETENTIONS THAT DID NOT RESULT IN A CONVICTION; CONVICTIONS THAT HAVE BEEN JUDICIALLY DISMISSED, EXPUNGED OR ORDERED SEALED; INFORMATION CONCERNING REFERRAL TO AND PARTICIPATION IN ANY PRETRIAL OR POSTTRIAL DIVERSION PROGRAM; AND CERTAIN DRUG RELATED CONVICTIONS THAT ARE OLDER THAN TWO YEARS, AS LISTED IN CALIFORNIA LABOR CODE § 432.8 (INCLUDING VIOLATIONS OF CALIFORNIA HEALTH AND SAFETY CODE SECTIONS 11357(B) AND (C), 11360(C) 11364, 11365 AND 11550 - AS THEY RELATE TO MARIJUANA)?

YES NO

IF YES, PLEASE EXPLAIN AND ATTACH ADDITIONAL SHEETS, IF NECESSARY.

PLEASE BRIEFLY EXPLAIN WHY YOU WISH TO SERVE ON THIS BOARD, COMMITTEE, OR COMMISSION. ATTACH ADDITIONAL SHEETS, IF NECESSARY.

It would be an honor to serve my fellow Veterans

DATE: 4/7/2021 APPLICANTS SIGNATURE: 

CLERK OF THE BOARD OF SUPERVISORS: USE ONLY. DO NOT WRITE BELOW THIS LINE.

Date Received: _____ Received by: _____ Deputy Clerk of the Board of Supervisors

Date referred: _____

To: BOS District 1 BOS District 2 BOS District 3 BOS District 4 BOS District 5

All BOS BCC Contact Person Name _____

Alexander C. Gonzalez

WORK EXPERIENCE

Military and Veterans Liaison / Field Representative

June 2019 – January 2021

Office of US Representative Harley Rouda (CA-48)

Newport Beach, CA

- Developed and managed military service academy nomination program resulting in over 60 nominations and 19 accepted appointments to date.
- Created private and public partnerships between regional 110+ member Community Veteran Engagement Board and local service providers.
- Processed 150+ Veteran Administration cases recovering \$1.1M+ in constituent savings.
- Fostered collaboration between federal, state, and local organizations to address systematic issues at the Orange County Veterans Service Office.
- Interacted directly with the City Council and City Managers of Huntington Beach and Costa Mesa.
- Engaged and replied to dozens of constituents regarding international affairs, trade, defense, intelligence, veterans' affairs, and labor issues each week.

Intelligence Specialist

September 2009 – February 2015

United States Navy

Various Locations

- Co-developed and initiated company-wide ride share program, resulting in 40% decrease in annual DUIs.
- Created and presented 200+ intelligence briefings to decision makers.
- Planned and prepared 40+ actionable intelligence reports for operational implementation.
- Managed \$30M classified information security program.
- Maintained library of 18,000 classified files.
- Trained 300+ staff on security control protocols.

Chairman

December 2015 – May 2018

Democrats Abroad

Tokyo, Japan

- Developed and executed campaign and outreach strategy to 3,000+ members for voter registration and party engagement activities.
- Raised and invested \$20,000 to increase voter turnout in Japan.

VOLUNTEER EXPERIENCE

American Legion Post 133, Huntington Beach, CA

March 2020 – Present

Veterans of Foreign Wars, Post 1054, Yokosuka, Japan

March 2017 – June 2019

EDUCATION

Temple University, Japan Campus, Tokyo Japan

August 2015 – May 2019

Bachelor of Arts in Political Science and International Relations; Minor in Asian Studies

LANGUAGES

- Native fluency in Spanish.
- Limited working proficiency in Japanese.



MEMORANDUM

To: Board of Supervisors

From: Katrina Foley

Date: April 12, 2021

CC: Office of the Clerk of the Board

Frank Kim, Chief Executive Officer

RE: Additional background information on 2nd District's supplemental agenda items for appointments to various boards, commissions and committees:

S43B – Appointment of Alexander Gonzalez of Costa Mesa to the Orange County Veterans Advisory Council is for a two year term ending 1/2/23 and replaces the expired term held by David Han.

S43C – Appointment of Michael Wellborn of Huntington Beach to the Orange County Parks Commission is for a term concurrent with the 2nd District Supervisor's term of office and replaces the expired term held by Michael Posey.

S43D – Appointment of Ada Briceño of Stanton to the Orange County Human Relations Commission is for a two year term that begins on date of appointment, 4/13/21 – 4/12/23, and replaces the expired term held by Michael Reynolds.

S43E – Appointment of Muriel Ullman of Newport Beach to the Housing and Community Development Commission is to complete the existing two year term that ends 6/30/21 and replaces the expired term held by James Fisler.

S43F – Appointment of David Lee of Corona Del Mar to the John Wayne Airport Arts Commission is for a term concurrent with the 2nd District Supervisor's term of office and replaces the expired term held by Stephanie Ann Bachiero.

S43G – Appointment of Lawrence Grihalva to the Emergency Medical Care Committee is to complete the existing two year term that ends 6/30/21 and replaces the expired term held by Jeffrey Barke.

S43H – Appointment of Rev. Rayna Hamre to the Community Action Partnership of Orange County is for a term concurrent with the 2nd District Supervisor's term off office and replaces the expired term held by Nimusha Punnen Jacob.

S43I – Appointment of Susan Dvorak to the Orange County Airport Commission is for a term concurrent with the 2nd District Supervisor's term of office and replaces the vacant position previously held by Lee Lowrey.



543C

MEMORANDUM

To: Clerk of the Board

From: Katrina Foley 

Date: April 7, 2021

RE: Appointment of Michael Wellborn to the Orange County Parks Commission

I would like to appoint Michael Wellborn to the Orange County Parks Commission.

Please place this item on the 4/13/21 agenda.

RECEIVED
CLERK OF THE BOARD

APR 07 2021



APPLICATION FOR COUNTY OF ORANGE
BOARD, COMMISSION OR COMMITTEE

(FOR COUNTY USE ONLY)

Return to:
Clerk of the Board of Supervisors
333 West Santa Ana Blvd., Suite 465
Santa Ana, California 92701
Website: www.ocgov.com/gov/cob/

Instructions: Please complete each section below. Be sure to enter the title of the Board, Commission or Committee for which you desire consideration. For information or assistance, please contact the Clerk of the Board of Supervisor's Office at (714) 834-2206. Please print in ink or type.

**NAME OF BOARD, COMMISSION, OR COMMITTEE TO WHICH YOU ARE APPLYING FOR MEMBERSHIP
(SEE LIST AT [HTTP://WWW.OCGOV.COM/GOV/COB/BCC/CONTACT](http://WWW.OCGOV.COM/GOV/COB/BCC/CONTACT)):**

Orange County Parks Commission

SUPERVISORIAL DISTRICT IN WHICH YOU RESIDE: First Second Third Fourth Fifth

APPLICANT NAME AND RESIDENCE ADDRESS:

Michael Wellborn

First Name

Middle Name

Last Name

Fountain Valley

Street Address

City

State

Zip Code

Home Phone Number Cell Phone Number

Email Address

CURRENT EMPLOYER: retired

OCCUPATION/JOB TITLE: n/a

BUSINESS ADDRESS:

BUSINESS PHONE NUMBER:

EMPLOYMENT HISTORY: Please attach a resume to this application and provide any information that would be helpful in evaluating your application.

ARE YOU A CITIZEN OF THE UNITED STATES: YES NO

IF NO, NAME OF COUNTRY OF CITIZENSHIP:

ARE YOU A REGISTERED VOTER? YES NO

IF YES, NAME COUNTY YOU ARE REGISTERED IN: Orange County

LIST ALL CURRENT PROFESSIONAL OR COMMUNITY ORGANIZATIONS AND SOCIETIES OF WHICH YOU ARE A MEMBER.

<u>ORGANIZATION/SOCIETY</u>	<u>FROM (MO./YR.)</u>	<u>TO (MO./YR.)</u>
<u>Friends of Harbors, Beaches and Parks</u>	<u>2007</u>	<u>Present</u>
<u>Orange County League of Conservation Voters</u>	<u>2014</u>	<u>Present</u>
<u>California Watershed Network</u>	<u>2001</u>	<u>Present</u>

WITHIN THE LAST FIVE YEARS, HAVE YOU BEEN AFFILIATED WITH ANY BUSINESS OR NONPROFIT AGENCY(IES)? YES NO

DO YOU OWN REAL OR PERSONAL PROPERTY OR HAVE FINANCIAL HOLDING WHICH MIGHT PRESENT A POTENTIAL CONFLICT OF INTEREST? YES NO

HAVE YOU BEEN CONVICTED OF A FELONY OR MISDEMEANOR CRIME SINCE YOUR 18TH BIRTHDAY? YOU ARE NOT REQUIRED TO DISCLOSE ANY OF THE FOLLOWING: ARRESTS OR DETENTIONS THAT DID NOT RESULT IN A CONVICTION; CONVICTIONS THAT HAVE BEEN JUDICIALLY DISMISSED, EXPUNGED OR ORDERED SEALED; INFORMATION CONCERNING REFERRAL TO AND PARTICIPATION IN ANY PRETRIAL OR POSTTRIAL DIVERSION PROGRAM; AND CERTAIN DRUG RELATED CONVICTIONS THAT ARE OLDER THAN TWO YEARS, AS LISTED IN CALIFORNIA LABOR CODE § 432.8 (INCLUDING VIOLATIONS OF CALIFORNIA HEALTH AND SAFETY CODE SECTIONS 11357(B) AND (C), 11360(C) 11364, 11365 AND 11550 – AS THEY RELATE TO MARIJUANA)?

YES NO

IF YES, PLEASE EXPLAIN AND ATTACH ADDITIONAL SHEETS, IF NECESSARY.

PLEASE BRIEFLY EXPLAIN WHY YOU WISH TO SERVE ON THIS BOARD, COMMITTEE, OR COMMISSION. ATTACH ADDITIONAL SHEETS, IF NECESSARY.

I have a strong interest in park lands and open spaces for both human recreation and for habitat.

DATE: 4-7-21

APPLICANTS SIGNATURE: 

CLERK OF THE BOARD OF SUPERVISORS USE ONLY – DO NOT WRITE BELOW THIS LINE

Date Received: _____ Received by: _____
Deputy Clerk of the Board of Supervisors

Date referred: _____

To: BOS District 1 BOS District 2 BOS District 3 BOS District 4 BOS District 5

All BOS BCC Contact Person Name _____

RESUME

Michael Wellborn

Principal, Michael Wellborn Consultant Services

December, 2011 to present

Focused on land use, open space and regulatory/enforcement issues.

Sales Associate, Recreational Equipment Inc.

Tustin, CA April, 2011 to August, 2019 (part-time)

**Administrative Manager/Zoning Administrator;
Chief, Code Enforcement Services**

OC Public Works Department

County of Orange

March 2004 to March 10, 2011 (*retired*)

Administrative Manager/Chief, Development Processing Center

Planning and Development Services Department

County of Orange

March 2003 to March 2004

Administrative Manager, Water Resources Programs

County of Orange – County Executive Office

July 2001 to March 2003

Senior Planner/Chief, Santa Ana River Section

Planning & Development Services Department

County of Orange

July 1990 to July 2001

Planner IV

Environmental Management Agency

County of Orange

October 1988 to July 1990

Staff Aide II, Planner I, II, III
Environmental Management Agency
County of Orange
September 1984 to October 1988

RELEVANT INVOLVEMENT AND MEMBERSHIPS:

- Zoning Administrator, County of Orange, May 2004 to March 2011
- Staff Support to National Research Council - Committee on Watershed Management, 1997
- Staff Support to the Orange County Water Task Force, 1992 to 2004
- County representative on Orange County Sanitation District's Strategic Plan Public Advisory Committee, 1998
- Member, Board of Directors, Friends of Harbors, Beaches and Parks
- Member, Santa Ana River Public Advisory Council
- Former Member, Board of Directors, Watershed Management Council
- Member, Board of Directors, California Watershed Network
- Member, Board of Directors, Orange County League of Conservation Voters
- Former Member, City of Fountain Valley Housing and Community Development Advisory Board, 2002 to 2013
- Participant, California Watershed Forums, 1999, 2000, 2003, 2005, 2007
- Delegate, National Watershed Forum, 2000
- Co-Founder, County of Orange, Watershed & Coastal Resources Division, 1999
- Co-Founder, Santa Ana Sucker Conservation Team, 1999

EDUCATION:

B.S. Conservation of Natural Resources	U.C. Berkeley	1978
Graduate	Carmel High School	1973



MEMORANDUM

To: Board of Supervisors

From: Katrina Foley

Date: April 12, 2021

CC: Office of the Clerk of the Board

Frank Kim, Chief Executive Officer

RE: Additional background information on 2nd District's supplemental agenda items for appointments to various boards, commissions and committees:

S43B – Appointment of Alexander Gonzalez of Costa Mesa to the Orange County Veterans Advisory Council is for a two year term ending 1/2/23 and replaces the expired term held by David Han.

S43C – Appointment of Michael Wellborn of Huntington Beach to the Orange County Parks Commission is for a term concurrent with the 2nd District Supervisor's term of office and replaces the expired term held by Michael Posey.

S43D – Appointment of Ada Briceño of Stanton to the Orange County Human Relations Commission is for a two year term that begins on date of appointment, 4/13/21 – 4/12/23, and replaces the expired term held by Michael Reynolds.

S43E – Appointment of Muriel Ullman of Newport Beach to the Housing and Community Development Commission is to complete the existing two year term that ends 6/30/21 and replaces the expired term held by James Fisler.

S43F – Appointment of David Lee of Corona Del Mar to the John Wayne Airport Arts Commission is for a term concurrent with the 2nd District Supervisor's term of office and replaces the expired term held by Stephanie Ann Bachiero.

S43G – Appointment of Lawrence Grihalva to the Emergency Medical Care Committee is to complete the existing two year term that ends 6/30/21 and replaces the expired term held by Jeffrey Barke.

S43H – Appointment of Rev. Rayna Hamre to the Community Action Partnership of Orange County is for a term concurrent with the 2nd District Supervisor's term off office and replaces the expired term held by Nimusha Punnen Jacob.

S43I – Appointment of Susan Dvorak to the Orange County Airport Commission is for a term concurrent with the 2nd District Supervisor's term of office and replaces the vacant position previously held by Lee Lowrey.



543D

MEMORANDUM

To: Clerk of the Board

From: Katrina Foley 

Date: April 7, 2021

RE: Appointment of Ada Briceño to the Orange County Human Relations Commission

I would like to appoint Ada Briceño to the Orange County Human Relations Commission.

Please place this item on the 4/13/21 agenda.

RECEIVED
CLERK OF THE BOARD
APR 07 2021



APPLICATION FOR COUNTY OF ORANGE BOARD, COMMISSION OR COMMITTEE

(FOR COUNTY USE ONLY)

RECEIVED CLERK OF THE BOARD

APR 07 2021

Return to: Clerk of the Board of Supervisors 333 West Santa Ana Blvd., Suite 465 Santa Ana, California 92701 Website: www.ocgov.com/gov/cob/

Instructions: Please complete each section below. Be sure to enter the title of the Board, Commission or Committee for which you desire consideration. For information or assistance, please contact the Clerk of the Board of Supervisor's Office at (714) 834-2206. Please print in ink or type.

NAME OF BOARD, COMMISSION, OR COMMITTEE TO WHICH YOU ARE APPLYING FOR MEMBERSHIP (SEE LIST AT HTTP://WWW.OCGOV.COM/GOV/COB/BCC/CONTACT):

Orange County Human Relations Commission

SUPERVISORIAL DISTRICT IN WHICH YOU RESIDE: [] First [x] Second [] Third [] Fourth [] Fifth

APPLICANT NAME AND RESIDENCE ADDRESS:

Ada Briceño
First Name Middle Name Last Name
Street Address City State Zip Code
Home Phone Number Cell Phone Number
Email Address

CURRENT EMPLOYER:

OCCUPATION/JOB TITLE:

BUSINESS ADDRESS:

BUSINESS PHONE NUMBER:

EMPLOYMENT HISTORY: Please attach a resume to this application and provide any information that would be helpful in evaluating your application.

ARE YOU A CITIZEN OF THE UNITED STATES: [x] YES [] NO

IF NO, NAME OF COUNTRY OF CITIZENSHIP:

ARE YOU A REGISTERED VOTER? [x] YES [] NO

IF YES, NAME COUNTY YOU ARE REGISTERED IN: Ada F. Briceño

LIST ALL CURRENT PROFESSIONAL OR COMMUNITY ORGANIZATIONS AND SOCIETIES OF WHICH YOU ARE A MEMBER.

<u>ORGANIZATION/SOCIETY</u>	<u>FROM (MO./YR.)</u>	<u>TO (MO./YR.)</u>
UNITE HERE	1991	Present
Democratic Party of Orange County	2017	Present
Democratic Party of California	2017	Present

WITHIN THE LAST FIVE YEARS, HAVE YOU BEEN AFFILIATED WITH ANY BUSINESS OR NONPROFIT AGENCY(IES)? YES NO

DO YOU OWN REAL OR PERSONAL PROPERTY OR HAVE FINANCIAL HOLDING WHICH MIGHT PRESENT A POTENTIAL CONFLICT OF INTEREST? YES NO

HAVE YOU BEEN CONVICTED OF A FELONY OR MISDEMEANOR CRIME SINCE YOUR 18TH BIRTHDAY? YOU ARE NOT REQUIRED TO DISCLOSE ANY OF THE FOLLOWING: ARRESTS OR DETENTIONS THAT DID NOT RESULT IN A CONVICTION; CONVICTIONS THAT HAVE BEEN JUDICIALLY DISMISSED, EXPUNGED OR ORDERED SEALED; INFORMATION CONCERNING REFERRAL TO AND PARTICIPATION IN ANY PRETRIAL OR POSTTRIAL DIVERSION PROGRAM; AND CERTAIN DRUG RELATED CONVICTIONS THAT ARE OLDER THAN TWO YEARS, AS LISTED IN CALIFORNIA LABOR CODE § 432.8 (INCLUDING VIOLATIONS OF CALIFORNIA HEALTH AND SAFETY CODE SECTIONS 11357(B) AND (C), 11360(C) 11364, 11365 AND 11550 – AS THEY RELATE TO MARIJUANA)?

YES NO

IF YES, PLEASE EXPLAIN AND ATTACH ADDITIONAL SHEETS, IF NECESSARY.

PLEASE BRIEFLY EXPLAIN WHY YOU WISH TO SERVE ON THIS BOARD, COMMITTEE, OR COMMISSION. ATTACH ADDITIONAL SHEETS, IF NECESSARY.

DATE: 4/7/21 APPLICANTS SIGNATURE: *Ada F. Briceno*

CLERK OF THE BOARD OF SUPERVISORS USE ONLY - DO NOT WRITE BELOW THIS LINE

Date Received: _____	Received by: _____ Deputy Clerk of the Board of Supervisors
Date referred: _____	
To: <input type="checkbox"/> BOS District 1 <input type="checkbox"/> BOS District 2 <input type="checkbox"/> BOS District 3 <input type="checkbox"/> BOS District 4 <input type="checkbox"/> BOS District 5	
<input type="checkbox"/> All BOS <input type="checkbox"/> BCC Contact Person Name _____	

Ada Briceño

Transformational Leadership for Justice and Equity

CAREER HISTORY

Co-President

UNITE HERE Local 11, 2017 - Present

- Represent 32,000 hospitality workers in Southern California and Arizona
- Responsible for budgets and all financial aspects of the organization
- Strategic planning and spokesperson representation
- Won [historic living wage initiatives](#) for thousands of workers in California
- [Led efforts](#) to end rampant sexual harassment in the hotel industry
- The [only major union](#) to launch full canvassing operations in the 2020 elections

Vice President

UNITE HERE International Union, 2015 - Present

- Voting body for a union representing 273,000 workers in US and Canada
- Approving budgets and voting on financial matters
- Approving programs to empower workers and people of color in the hospitality industry

Interim Executive Director

Orange County Communities Organized for Responsible Development (OCCORD) - 2015-2016

- Led fundraising and donor relationship development
- Managing staff and board of directors
- Managed strategic planning and served as spokesperson for the organization

Secretary Treasurer

UNITE HERE Local 11, 2008 to 2017

- Oversee all financial aspects of the organization
- Manage all administrative personnel

- Oversee the grievance and legal sections of the Union
- Leading political and community relations for Orange County

President

UNITE HERE Local 681, June 2001 - 2008

- Representing 7,000 hospitality workers in Orange County and Long Beach
- Running operations including hiring, managing, training and firing of staff
- Strategic planning and spokesperson for the organization
- Running all budgeting and financial aspects of the organization
- Representing workers' interests at state and national levels

COMMUNITY LEADERSHIP

- South Coast Air Quality Management District Environmental Justice Advisory Committee - Committee Member
- Orange County Clergy and Laity United for Economic Justice (CLUE) - Former Chair
- Orange County Communities Organized for Responsible Development (OCCORD) - Founder and Former Board Chair
- Orange County Women's March - Steering Committee Member, 2017-Onwards
- Democratic Party of Orange County - Chairwoman, 2019-Onwards
- Democratic National Committee - Committee Member, California
- Labor Campaign for Single-Payer - National Steering Committee Member
- California Democratic Party Finance Committee - Lead Co-Chair
- California Democratic Party Ad Hoc Committee on Committee Diversity, Equity and Inclusion - Former Lead Chair

AWARDS

- Orange County's "100 Most Influential" - Orange County Register - 2020, 2019, 2018 and 2014
- Hispanic Bar Association "Guardian de Justicia" - March 2020
- California Democratic Party "Regional Director's Award" - 2019
- The Women's Journey Foundation "2019 Legacy Award"
- Planned Parenthood Community Action Fund "2018 Honoree"
- Women for: Orange County - 2018 Award
- Assemblymember Sharon Quirk-Silva "2018 Women of Distinction"

- Cesar E. Chavez Commemorative Committee SFV "Warrior of Justice" - 2017
- We Lead OC - 2017 Honoree
- 72nd ADA Democratic Club "Flag Day Awards" - 2017
- OCCCCO "Faith in Democracy" - June 2017
- Department of History at California State University of Fullerton "Voces de Liberacion" Latinas and Politics in Southern California Exhibition - 2017
- Los Angeles Federation of Labor "Miguel Contreras Leadership Award" - 2012

ACADEMIC DEVELOPMENT

Cornell University

National Labor Leadership Initiative, 2020

Advanced Leadership Program, 2021



MEMORANDUM

To: Board of Supervisors

From: Katrina Foley

Date: April 12, 2021

CC: Office of the Clerk of the Board

Frank Kim, Chief Executive Officer

RE: Additional background information on 2nd District's supplemental agenda items for appointments to various boards, commissions and committees:

S43B – Appointment of Alexander Gonzalez of Costa Mesa to the Orange County Veterans Advisory Council is for a two year term ending 1/2/23 and replaces the expired term held by David Han.

S43C – Appointment of Michael Wellborn of Huntington Beach to the Orange County Parks Commission is for a term concurrent with the 2nd District Supervisor's term of office and replaces the expired term held by Michael Posey.

S43D – Appointment of Ada Briceño of Stanton to the Orange County Human Relations Commission is for a two year term that begins on date of appointment, 4/13/21 – 4/12/23, and replaces the expired term held by Michael Reynolds.

S43E – Appointment of Muriel Ullman of Newport Beach to the Housing and Community Development Commission is to complete the existing two year term that ends 6/30/21 and replaces the expired term held by James Fisler.

S43F – Appointment of David Lee of Corona Del Mar to the John Wayne Airport Arts Commission is for a term concurrent with the 2nd District Supervisor's term of office and replaces the expired term held by Stephanie Ann Bachiero.

S43G – Appointment of Lawrence Grihalva to the Emergency Medical Care Committee is to complete the existing two year term that ends 6/30/21 and replaces the expired term held by Jeffrey Barke.

S43H – Appointment of Rev. Rayna Hamre to the Community Action Partnership of Orange County is for a term concurrent with the 2nd District Supervisor's term off office and replaces the expired term held by Nimusha Punnen Jacob.

S43I – Appointment of Susan Dvorak to the Orange County Airport Commission is for a term concurrent with the 2nd District Supervisor's term of office and replaces the vacant position previously held by Lee Lowrey.



543E

MEMORANDUM

To: Clerk of the Board

From: Katrina Foley 

Date: April 7, 2021

RE: Appointment of Muriel Ullman to the Orange County Housing and Community Development Commission

I would like to appoint Muriel Ullman to the Orange County Housing and Community Development Commission.

Please place this item on the 4/13/21 agenda.

RECEIVED
CLERK OF THE BOARD

APR 07 2021

Orange County Housing Authority

**APPLICATION FOR
HOUSING AND COMMUNITY DEVELOPMENT COMMISSION**

NAME: Muriel Ullman

RESIDENTIAL ADDRESS: _____
STREET ADDRESS CITY STATE NPBCA

HOW LONG AT THIS ADDRESS? _____ DAYTIME TELEPHONE: _____

ARE YOU A CITIZEN OF THE UNITED STATES? YES NO

NAME OF COUNTRY OF CITIZENSHIP: USA

ARE YOU A REGISTERED VOTER? YES NO

IF YES, NAME COUNTY YOU ARE REGISTERED IN: OC

Within the last five years, have you been affiliated with any business or nonprofit agency(ies)?

YES NO

Do you own real estate or personal property or have financial holdings, which might present a potential conflict of interest, including, but not limited to housing assistance payments contracts with the Orange County Housing Authority?

YES NO

If yes to either question, please explain.

List all current professional or community organizations and societies of which you are a member:

NAME OF ORGANIZATION Fresh Beginnings Minist. DATES OF MEMBERSHIP 2015

NAME OF ORGANIZATION JCC DATES OF MEMBERSHIP 13 years

Have you been convicted of a felony or misdemeanor crime since your 18th birthday, excluding arrests of detentions that did not result in a conviction; convictions that have been judicially dismissed, expunged or ordered sealed; and certain marijuana related convictions that are older than two years, as listed in California Labor Code § 432.8 (including violations of California Health and Safety Code Sections 11357(B) AND (C), 11360(C) 11364, 11365 AND 11550 - as they relate to marijuana)? YES NO

If yes, please explain.

In the absence of special circumstances, which allow for meetings to be conducted via teleconference, regular meetings are generally held in-person on the 4th Thursday of each month from 10:00 a.m. to 12:00 p.m. at the Public Library Headquarters located at 1501 E. St. Andrew Place in Santa Ana.

Can you attend regularly?

YES NO

SIGNATURE DATE 4/6

Please complete the attached supplemental questions and submit your responses with this application and your resume.

**SUPPLEMENTAL QUESTIONNAIRE
HOUSING AND COMMUNITY DEVELOPMENT COMMISSION**

1. Please explain your interest in serving on the H&CD Commission.

1) Former Hous Prof. - 20 years
2) Consultant for comm. outreach
+ homeless services for over 10 years

2. In addition to activities related to the Orange County Housing Authority, Commission members also vote on recommendations for affordable housing developments and a variety of community development projects. Do you have any related experience, training or knowledge that makes you a good candidate to provide objective input and recommendations on a variety of housing related issues?

1) MS Urban Planning
2) 30 years as housing prof + homeless
consultant for Costa Mesa, Santa Ana, HB, Redondo

3. H&CD Commission members include five representatives appointed by the Board of Supervisors, two from the Cities Selection Committee, two At-Large members and two tenants who are receiving housing assistance. If selected, what perspective can you bring to this group?

Local gov. perspective both as
property owner + hous. professional

4. The H&CD Commission requires a commitment generally on the fourth Thursday of each month. Do you foresee any challenges attending these meetings on a regular basis? Are there any conflicts of interest that may arise with your appointment to the H&CD Commission?

NO

5. Do you have any business associations, affiliations, contracts, or any other involvement in an activity(ies) that could be a conflict interest?

NO

6. Is there any other information you would like to share?

I'm a dedicated community
volunteer + professional who
has a balanced business residential perspective
with regard to policy + housing

Muriel Ullman

CAREER

OBJECTIVE:

A consulting position in either the public or the private sector

SKILLS SUMMARY

- 40 years of administrative experience including supervision of up to 8 employees, management of \$3,000,000 budget and implementation of numerous homeless and community development programs
- Experience in presentations, customer relations, community outreach, grant writing, volunteer coordination and group facilitation for community organizations and committees
- Extensive program management experience from development through implementation for both public and nonprofit organizations

WORK

EXPERIENCE:

2009-Present

HOUSING/HOMELESS CONSULTANT

- Development of a homeless strategy designed to reduce homelessness in Costa Mesa and other neighboring cities
- Coordination of Homeless Task Force and Neighborhood improvement Task Force including meeting planning, facilitation, presentations
- Development of strategic network of non profits, public safety, and faith based alliance in order to address community problems and nuisance properties
- Policy recommendations and operations guidance regarding creation of an emergency homeless shelter based on lawsuit settlement
- Operations and management guidance for local non profit specializing in homeless services

1991-2009

City of Costa Mesa, Costa Mesa, California

NEIGHBORHOOD IMPROVEMENT MANAGER

- Administration of Redevelopment and Housing and Community Development Division including HOME programs, Community Development Block Grant and Redevelopment set-aside housing projects
- Monitoring and administration of publically funded affordable housing projects

1986-1991

City of Long Beach, Long Beach, California

DEVELOPMENT PROJECT MANAGER

- Implementation of Downtown and Industrial Development Projects including Project Planning, Development of Design Guidelines, Entitlement Processing, Developer Negotiations and Construction Management

1985-1986

Urban Futures, Inc., Fullerton, California

SENIOR PLANNER

- Preparation and Management of Downtown Plans, Redevelopment Plans, Specific Plans, General Plans and Environmental Impact Reports

VOLUNTEER EXPERIENCE

- Bureau of Jewish Education – Past Board Member
- Congregation B'nai Israel – Past Membership Vice President
- Fresh Beginnings Ministries – Assistant General Manager
- JCC Cares - Steering Committee
- Mental Health Association - Past Board Member

EDUCATION

UNIVERSITY OF SOUTHERN CALIFORNIA, Los Angeles
Masters in Urban and Regional Planning

1983

UNIVERSITY OF CALIFORNIA, Berkeley
**Bachelor of Arts, Communications and Public Policy and
Psychology**

1976

**COMPUTER
SKILLS**

Microsoft Office Applications

REFERENCES

Available upon request



MEMORANDUM

To: Board of Supervisors

From: Katrina Foley

Date: April 12, 2021

CC: Office of the Clerk of the Board

Frank Kim, Chief Executive Officer

RE: Additional background information on 2nd District's supplemental agenda items for appointments to various boards, commissions and committees:

S43B – Appointment of Alexander Gonzalez of Costa Mesa to the Orange County Veterans Advisory Council is for a two year term ending 1/2/23 and replaces the expired term held by David Han.

S43C – Appointment of Michael Wellborn of Huntington Beach to the Orange County Parks Commission is for a term concurrent with the 2nd District Supervisor's term of office and replaces the expired term held by Michael Posey.

S43D – Appointment of Ada Briceño of Stanton to the Orange County Human Relations Commission is for a two year term that begins on date of appointment, 4/13/21 – 4/12/23, and replaces the expired term held by Michael Reynolds.

S43E – Appointment of Muriel Ullman of Newport Beach to the Housing and Community Development Commission is to complete the existing two year term that ends 6/30/21 and replaces the expired term held by James Fisler.

S43F – Appointment of David Lee of Corona Del Mar to the John Wayne Airport Arts Commission is for a term concurrent with the 2nd District Supervisor's term of office and replaces the expired term held by Stephanie Ann Bachiero.

S43G – Appointment of Lawrence Grihalva to the Emergency Medical Care Committee is to complete the existing two year term that ends 6/30/21 and replaces the expired term held by Jeffrey Barke.

S43H – Appointment of Rev. Rayna Hamre to the Community Action Partnership of Orange County is for a term concurrent with the 2nd District Supervisor's term off office and replaces the expired term held by Nimusha Punnen Jacob.

S43I – Appointment of Susan Dvorak to the Orange County Airport Commission is for a term concurrent with the 2nd District Supervisor's term of office and replaces the vacant position previously held by Lee Lowrey.



S43F

MEMORANDUM

To: Clerk of the Board

From: Katrina Foley 

Date: April 7, 2021

RE: Appointment of David Lee to the John Wayne Airport Arts Commission

I would like to appoint David Lee to the John Wayne Airport Arts Commission.

Please place this item on the 4/13/21 agenda.

RECEIVED
CLERK OF THE BOARD

APR 07 2021



APPLICATION FOR COUNTY OF ORANGE
BOARD, COMMISSION OR COMMITTEE

(FOR COUNTY USE ONLY)

Return to:

Clerk of the Board of Supervisors
333 West Santa Ana Blvd., Suite 465
Santa Ana, California 92701
Website: www.ocgov.com/gov/cob/

RECEIVED
CLERK OF THE BOARD

APR 07 2021

Instructions: Please complete each section below. Be sure to enter the title of the Board, Commission or Committee for which you desire consideration. For information or assistance, please contact the Clerk of the Board of Supervisor's Office at (714) 834-2206. Please print in ink or type.

**NAME OF BOARD, COMMISSION, OR COMMITTEE TO WHICH YOU ARE APPLYING FOR MEMBERSHIP
(SEE LIST AT [HTTP://WWW.OCGOV.COM/GOV/COB/BCC/CONTACT](http://www.ocgov.com/gov/cob/bcc/contact)):**

Airport Arts Commission

SUPERVISORIAL DISTRICT IN WHICH YOU RESIDE: First Second Third Fourth Fifth

APPLICANT NAME AND RESIDENCE ADDRESS:

David Michael Lee
First Name Middle Name Last Name

Street Address City State Zip Code

Home Phone Number Cell Phone Number

Email Address

CURRENT EMPLOYER: _____

OCCUPATION/JOB TITLE: _____

BUSINESS ADDRESS: _____

BUSINESS PHONE NUMBER: _____

EMPLOYMENT HISTORY: Please attach a resume to this application and provide any information that would be helpful in evaluating your application.

ARE YOU A CITIZEN OF THE UNITED STATES: YES NO

IF NO, NAME OF COUNTRY OF CITIZENSHIP: _____

ARE YOU A REGISTERED VOTER? YES NO

IF YES, NAME COUNTY YOU ARE REGISTERED IN: Orange County

LIST ALL CURRENT PROFESSIONAL OR COMMUNITY ORGANIZATIONS AND SOCIETIES OF WHICH YOU ARE A MEMBER.

ORGANIZATION/SOCIETY	FROM (MO./YR.)	TO (MO./YR.)
Lions Club	1/2016	

WITHIN THE LAST FIVE YEARS, HAVE YOU BEEN AFFILIATED WITH ANY BUSINESS OR NONPROFIT AGENCY(IES)? YES NO

DO YOU OWN REAL OR PERSONAL PROPERTY OR HAVE FINANCIAL HOLDING WHICH MIGHT PRESENT A POTENTIAL CONFLICT OF INTEREST? YES NO

HAVE YOU BEEN CONVICTED OF A FELONY OR MISDEMEANOR CRIME SINCE YOUR 18TH BIRTHDAY? YOU ARE NOT REQUIRED TO DISCLOSE ANY OF THE FOLLOWING: ARRESTS OR DETENTIONS THAT DID NOT RESULT IN A CONVICTION; CONVICTIONS THAT HAVE BEEN JUDICIALLY DISMISSED, EXPUNGED OR ORDERED SEALED; INFORMATION CONCERNING REFERRAL TO AND PARTICIPATION IN ANY PRETRIAL OR POSTTRIAL DIVERSION PROGRAM; AND CERTAIN DRUG RELATED CONVICTIONS THAT ARE OLDER THAN TWO YEARS, AS LISTED IN CALIFORNIA LABOR CODE § 432.8 (INCLUDING VIOLATIONS OF CALIFORNIA HEALTH AND SAFETY CODE SECTIONS 11357(B) AND (C), 11360(C) 11364, 11365 AND 11550 – AS THEY RELATE TO MARIJUANA)?

YES NO

IF YES, PLEASE EXPLAIN AND ATTACH ADDITIONAL SHEETS, IF NECESSARY.

PLEASE BRIEFLY EXPLAIN WHY YOU WISH TO SERVE ON THIS BOARD, COMMITTEE, OR COMMISSION. ATTACH ADDITIONAL SHEETS, IF NECESSARY.

I am an arts advocate.

DATE: 4/7/2021

APPLICANTS SIGNATURE: 

CLERK OF THE BOARD OF SUPERVISORS USE ONLY - DO NOT WRITE BELOW THIS LINE

Date Received: _____ Received by: _____
Deputy Clerk of the Board of Supervisors

Date referred: _____

To: BOS District 1 BOS District 2 BOS District 3 BOS District 4 BOS District 5

All BOS BCC Contact Person Name _____

David Michael Lee...

Born and raised in Southern California, I hold a BA in photo/studio arts from Columbia College Chicago, and an MFA in drawing, painting and printmaking from California State University Fullerton. I have worked in higher education since 2002 teaching these classes. In addition to teaching I have also worked in museums, galleries and art centers, handling art, curating and organizing private and public art collections.

My art is in a handful of private collections, university collections as well as public, including the Orange County Museum of Art.

Education:

MFA, Cal State University Fullerton, 2004 - Painting / Drawing / Printmaking
BA, Columbia College Chicago, 2001- Painting / Photography
Centro Linguistico Dante Alighieri, Florence IT 1996 – Painting / History
Orange Coast College, 1995 - 1998 - General Education

Teaching Experience:

Coastline Community College • Assistant Professor (2013 -
Chapman University • 2D Design/Drawing (2006 – 2012)
Orange Coast College • 2D Design (2006 – 2011)
Santa Ana College • Drawing/History/Artforum (2005 – 2011)
Fullerton Community College • Painting (2004 – 2005)
Cal State University Fullerton • Painting/Drawing (2002 – 2005)

Professional Experience:

Coastline Art Gallery • Curator/Director (2011 -
Chapman University • Interim University Curator • (2011-2012)
Chapman University • Collections Manager (2001 - 2011)
Chapman University • Guggenheim Gallery Preparator (2001 – 2011)
Grand Central Art Center • Assistant to Director / Resident Advisor (2001 - 2004)
Independent Fabrication/Installation/Graphic Design (Since 1996)
Studio Assistant • Tony Delap (1996 - 2012)
Studio Assistant • Tom Dowling (1996 - 1999)
Santa Ana Seven • Art Collaborative (2002 - 2005)
Downtown Santa Ana Business Council • Board of Directors/Art Grant (2004 - 2009)
Orange County Center for Contemporary Arts • Advisory Board (2008 – 2012)

Solo Exhibitions:

Succession • Jamie Brooks Fine Art • Costa Mesa, CA 2016
Spaced Out • Brett Rubbico Gallery • Newport Beach, CA 2012
Good Bad Ugly • Backroom • Santa Ana, CA • 2007
I Heart Painting • Grand Central Art Center • Santa Ana, CA • 2006
davidmichaellee • Chapman University/Henley Galleria • Orange, CA • 2005
Concepts and Volcanoes • L2Kontemporary • Los Angeles, CA • 2005
Flight Evolution and Human Nature • CSUF West Gallery, CA • 2003

Group Exhibitions:

2019
two • cubed, OCCCA, Santa Ana, CA
Kitsch-in-Sync, Coastline Art Gallery, Newport Beach, CA
2018
Color Vision, HBAC, Huntington Beach, CA
2017

Abstract Miniatures, Fine Art Complex 1011, Tempe, AZ
Abstraction in the Singular: Part II, Bentley Gallery. Phoenix, AZ
2016
MAS Attack 12, San Diego Art Institute, San Diego, CA
2015
Currents, Jamie Brooks Fine Art, Costa Mesa, CA
SFO/SNA, City College Gallery, San Francisco, CA
SFO/SNA, Coastline Art Gallery, Newport Beach, CA
Surface Tension, F+ Gallery, Santa Ana, CA
Within our Nature, Logan Creative, Santa Ana, CA
Mirrors and Windows, Copper Mountain College, Joshua Tree, CA 2014
The Art of the Heist, Laguna Art Museum, Laguna Beach, CA
Auction, Orange County Museum of Art, Newport Beach, CA
OC Academy, Irvine Fine Art Center, Irvine, CA
The Living Room, Orange County Great Park, Irvine, CA
Around the Corner, Santa Ana College, Santa Ana, CA
BEHOLD, Brett Rubbico Gallery, Newport Beach, CA
Foot High, SCA, Pomona, CA
2013
Ten Years Drawn, L2Kontemporary, Los Angeles, CA
Sense and Sensibility I, Mt. SAC Art Gallery, Walnut, CA
Summer Group Show, Brett Rubbico Gallery, Newport Beach, CA
2012
Abstract Expressionism, Santa Ana College, Santa Ana, CA
Painting on Edge • Autonomie, Los Angeles, CA
Painting on Edge II • D.E.N. Contemporary • Los Angeles, CA
2011
La Costa Nostra • Gallerie Rheeway, Los Angeles, CA
Nue Brucke • Autonomie, Los Angeles, CA
Mailin' It In, A Group Invitational • Chicago Street Gallery, Chicago, IL
Speculative Materialism II • Andi Campongnone, Pomona, CA
MayJune Gallery • Seoul Open Art Fair, Seoul, Korea
D-Block Projects, Long Beach, CA
Coastline Community College, Faculty Exhibition, Huntington Beach, CA
A Dynamic Approach • Galerie Rheeway, Los Angeles, CA
Suspended in Space • OCFAS, Anaheim, CA
Mailin' It In, A Group Invitational • The Nicole Villeneuve Gallery Chicago, IL
2010
Commonspace L.A. • ACTION (Un)PACKED: ABSTRACTION AFTER ACTION, LA, CA
Coastline Community College, Huntington Beach, CA
New Used Borrowed, Guggenheim Gallery, Orange CA
100 Artists See Satan Again, GCAC. Santa Ana, CA
Best, Crussell Fine Arts, Orange, CA
The Camp, Homegrown, Costa Mesa, CA
Santa Ana College Faculty Show, SAC Santora, Santa Ana, CA
2009
Looking into the Sun • DDR Projects, Long Beach, CA
Driven to Abstraction • Coastline Community College, Huntington Beach, CA
From Scratch • Chicago Art Source, Chicago, IL
The Abstract Truth • Roark, Los Angeles, CA
Eclat • Crussell Fine Art, Orange, CA
Invasion • @space contemporary, Santa Ana, CA
2008
Cusp • Crussell Fine Arts, Orange, CA
Alumni Exhibition • CSUF Main Gallery, Fullerton, CA
Flat Land • @space • Santa Ana, CA

Drawing Extended • Coastline Community College, Huntington Beach, CA

Evolutionary Refinement • Grand Central Art Center, Santa Ana, CA

About Abstraction • Chapman's Guggenheim Gallery, Orange, CA

Group Love • Back Room • Santa Ana, CA

Faculty Exhibition • Orange Coast College • Costa Mesa, CA

2007

Group Show • Sabina Lee • Los Angeles, CA

Subset • Crussell Fin Art • Orange, CA

Local Motion • GCAC • Santa Ana, CA

Voyage • @space contemporary, Santa Ana, CA

Tales of the South Pacific • Saddleback College • Mission Viejo, CA

Something's Brewing, • CO-OPs Mid-manifestation • Sonnenborgh Museum and Sterrenwacht, Utrecht, the Netherlands,

PlayitGround • Don O'Melveny Gallery • Los Angeles, CA

Winter Button Up • Tense Forms • Chicago, IL 2006

Oscene II • Laguna Beach Museum of Art • Laguna Beach, CA

3 Diety • Koo's Cafe • Long Beach, CA

The Enthusiastic Eye • Guggenheim Gallery • Orange, CA

2005

The Bird Show • Grand Central Art Center • Santa Ana, CA

SA7 Strikes Again • Fullerton College • Fullerton, CA

Genesis • San Luis Obispo Art Center • SLO, CA

Problem with Authority • Grand Central Art Center • Santa Ana, CA

POP • The Office • Huntington Beach, CA 2004

Secondennial • Square Blue • Costa Mesa, CA

In-between Flight • The Wine Room • Irvine, CA

Art Department Biennial • Fullerton College • Fullerton, CA

The War Ascetic • Pece/Arieas Gallery • Santa Ana, CA

Free Range Artist • Legacy • Santa Ana, CA

2004

Critique • East/West Gallery • Fullerton CA

2003

Beefcake Cheesecake 2 • OCCCA • Santa Ana, CA

Waiting for Fame • Memphis/Santa Ana 7 • Santa Ana, CA

Velvet Dreams • Lava Lounge • Seattle, WA

Abstracted Four • SCA Gallery • Pomona, CA

Eight Case of Santa Ana Seven • Henley Galleria • Orange, CA

A Remembrance of things Past • East/West Gallery • Fullerton, CA

Pigment to Dye • The Shed • Newport Beach, CA

Choices • Exit Gallery • Fullerton, CA

Mustache/Mistache for Peace • Memphis/Santa Ana 7 • Santa Ana, CA

4th Street Mural Project • Santa Ana, CA

F.L.Y. • Bob Pece/Jones • Santa Ana, CA

2002

Rock Hard Abs Traction • Memphis • Santa Ana, CA

The Gun Show • Soil Gallery • Seattle, WA

4th Street Mural Project • Santa Ana, CA

Uncomfortably Comfortable • Exit Gallery • Fullerton, CA

Charting The Paths of Color • GCAC • Santa Ana, CA

New Voices • Suburban Fine Art Center • Highland Park, IL 2001

Ray Guns and Declarations • GCAC • Santa Ana, CA

Fresh • Glass Curtain Gallery • Chicago, IL

Creativity With A Conscience • Hokin Gallery • Chicago, IL

2000

50/50 • Glass Curtain Gallery • Chicago, IL

Coastline Art Gallery Exhibitions:

Try to See it my Way, Spring 2020
Desert|Dessert, Fall 2020
Kitsch - in - Sync, Spring 2019
Trifecta Faculty Exhibition, Fall 2018
Fish Out of Water, Fall 2018
Ribba 4 Spring 8
On The Ropes/ In the Kissers, Spring 2018
Pairing UP (Faculty with Veterans), Fall 2017
Strings Attached Fiber, Fall 2017
RIBBA 3 - Community Art/ Diversity Day, Spring 2017
WORKS ON PAPER, Spring 2017
LIKE MARK, Fall 2017
RIBBA 2, Spring 2016
BIRDIE 2/5 - 3/18/2016
SFO/SNA, Fall 2015
ORANGE SUNSHINE and the Mystic Artists, Fall 2015
SPRING | Idiom, Spring 2015
ABSTRACT/ elevations, Spring 2015
FARM| 2 Fork, Fall 2014
RIBBA| 500, Fall 2014
Selections From The Festival Of Arts Permanent Collection, Summer 2014
Spaghetti Western, Spring 2014
Stock California, Spring 2014
Pretty Awesome, Fall 2013
Allegory Cave, Summer/Fall 2013
Making Working, Spring 2013
Next to Nothing, Spring 2013
Commodores, Fall 2012
CAKE|fondant, Fall 2012
Summer of Abstraction, Summer 2012
Photo + Plus, Spring 2012
Transition:figure, Fall 2011

Exhibitions Organized:**The Back Room at Memphis Santora:**

Rock Hard Abstractions, December 2002
Mustache/Mistache for Peace, April 2003
Waiting for Fame, September 2003
Men of Grand Central, December 2003
Love Gardens, April 2004
Cones, September 2004
Horizon, Fullerton College, December 2004
Mathew Price, March 2005
Gretchen Potts, May 2005
Edwin James Maguire, June 2005
Various Scraps of Fabric, davidmichaellee, January 2006
Fables of Impending Doom, Jason Rutherford, February 2006
Terminal Island: End of the world, Anne Handberry, March 2006
Tom Dowling, Madonna Inn, April 2006
Travis Collinson, May 2006
Post Organic, Robert Arieas, June 2006
CSUF Student show, July 2006
Claudia McCain, August 2006

Glenn Brooks, September 2006
Amy Hernandez, October 2006
Sin & Circuitry, Robert Arieas, November 2006
Memories in the Making – Alzheimers Association, December 2006
Good Bad Ugly, davidmichaellee, February 2007
John Gilhooley, April 2007
Amy Linder, Woven Material, May 2007
States of Cultification, Ryan Scheit, July 2007
Bones of the Earth, Richard Turner, August 2007
This Place, Robert Miller, September 2007
Robert Arieas, October 2007
His Floating Hair, Richard Turner, October 2007
Works on Paper, davidmichaellee, November 2007
R.T.Pece, December 2007
Portals, Passages and Thresholds, Tom and Lisa Dowling, January 2008
Group Love, February 2008
Eric Takach, Ryan Norgren, March 2008
John Gilhooley, April 2008
Patrick Strand, February 2009
Baroque-A-Doke, Reafsnyder, Kiddie, Rowntree, Davies, March 2009
John Gilhooley, May 2009
Young Masters, Temple Betel, May 2009
Coulrophobic, Danny Morales, June 2009
John Gilhooley, April 2010
Guy White, September 2010
David and Robert, September 2011
Dead Alive, November 2011
Me and You, December 2011

Chapman University Exhibitions:

Alphabet, Jan/Feb 2012
Eight Cases of Santa Ana Seven, July 2003
About Abstraction, July 2008
Tony Delap, November, 2008 (organized w/ Maggi Owens)
New Used Borrowed, July 2010

Fullerton College:

Santa Ana Seven Strikes Again, July 2005

Grand Central Art Center:

The Bird Show, August 2005

Santa Ana College:

Art Forum Exhibition, Fall 2009 (organized w/ Phil Marquez)

The Wine Room:

New Finish, Dan Rossiter, February 2004
New Work, Mathew Price, April 2004
In Between Flight, Robert Arieas, davidmichaellee, October 2004
Anthony Gordon, January 2005

Installations and at @space Contemporary:

Progressive Shift: Ryan Scheidt, Elaine Coombs, May 2007
Space for Utopia: Michelle Wasson, Seann Brackin, June 2007
What Would I Wear If: Robbie Miller, July 2007
Voyage: Grup Show, August 2007

Moments Happen: Glenn Fischer, September 2007
True Hallucinations: Jane Bauman, October 2007
The Feeling of Being: Evan apRoberts, November 2007
Courting Allusion: Alison Foshee & Sara Simon, December 2008
Hairshirt: Max King Cap, January 2008
Dreams of Floating/Dreams of Falling: Jason Rutherford, March 2008
Eoin Breadon / Jason Chakravarty • An Indian and an Irishman Walk Into a Bar, April 2008
Dual Perspectives: Nobuhito Nishigawara, May 2008
Object: Brandon Anschutz, July 2008
Flatland: Group Show, August 2008
Small Works and Short Films: Sam Erenberg, October 2008
Naturally Synthetic: Groupshow, November 2008
Imago Ignota: Jay Sagan, December 2008
Invasion: David Michael Lee, Anthony Gordon, January 2009
Here and Now: Tom Dowling, March 2009
Apophenia: Jane Bauman, April 2009
Reperio Partum Verum: A Discrete Collective, June 2009

Orange County Arts Grant:

A four-year project awarding over \$20,000 to artists in the community and the design, publication and distribution of a full-color catalog of the awardees.

ArtForum Santa Ana College:

Organized lecture in conjunction with the Art 100 Course.

Coastline Community College EBUS:

Online art history course with Xiang Jiang High School, Guangzhou CN, Dec.–Jan. on site.



MEMORANDUM

To: Board of Supervisors

From: Katrina Foley

Date: April 12, 2021

CC: Office of the Clerk of the Board

Frank Kim, Chief Executive Officer

RE: Additional background information on 2nd District's supplemental agenda items for appointments to various boards, commissions and committees:

S43B – Appointment of Alexander Gonzalez of Costa Mesa to the Orange County Veterans Advisory Council is for a two year term ending 1/2/23 and replaces the expired term held by David Han.

S43C – Appointment of Michael Wellborn of Huntington Beach to the Orange County Parks Commission is for a term concurrent with the 2nd District Supervisor's term of office and replaces the expired term held by Michael Posey.

S43D – Appointment of Ada Briceño of Stanton to the Orange County Human Relations Commission is for a two year term that begins on date of appointment, 4/13/21 – 4/12/23, and replaces the expired term held by Michael Reynolds.

S43E – Appointment of Muriel Ullman of Newport Beach to the Housing and Community Development Commission is to complete the existing two year term that ends 6/30/21 and replaces the expired term held by James Fidler.

S43F – Appointment of David Lee of Corona Del Mar to the John Wayne Airport Arts Commission is for a term concurrent with the 2nd District Supervisor's term of office and replaces the expired term held by Stephanie Ann Bachiero.

S43G – Appointment of Lawrence Grihalva to the Emergency Medical Care Committee is to complete the existing two year term that ends 6/30/21 and replaces the expired term held by Jeffrey Barke.

S43H – Appointment of Rev. Rayna Hamre to the Community Action Partnership of Orange County is for a term concurrent with the 2nd District Supervisor's term off office and replaces the expired term held by Nimusha Punnen Jacob.

S43I – Appointment of Susan Dvorak to the Orange County Airport Commission is for a term concurrent with the 2nd District Supervisor's term of office and replaces the vacant position previously held by Lee Lowrey.



5436

MEMORANDUM

To: Clerk of the Board

From: Katrina Foley 

Date: April 7, 2021

RE: Appointment of Lawrence Grihalva to the Emergency Medical Care Committee

I would like to appoint Lawrence Grihalva to the Emergency Medical Care Committee.

Please place this item on the 4/13/21 agenda.

RECEIVED
CLERK OF THE BOARD

APR 07 2021



APPLICATION FOR COUNTY OF ORANGE BOARD, COMMISSION OR COMMITTEE

(FOR COUNTY USE ONLY)

Return to:

Clerk of the Board of Supervisors
333 West Santa Ana Blvd., Suite 465
Santa Ana, California 92701
Website: www.ocgov.com/gov/cob/

RECEIVED CLERK OF THE BOARD

APR 07 2021

Instructions: Please complete each section below. Be sure to enter the title of the Board, Commission or Committee for which you desire consideration. For information or assistance, please contact the Clerk of the Board of Supervisor's Office at (714) 834-2206. Please print in ink or type.

NAME OF BOARD, COMMISSION, OR COMMITTEE TO WHICH YOU ARE APPLYING FOR MEMBERSHIP (SEE LIST AT HTTP://WWW.OCGOV.COM/GOV/COB/BCC/CONTACT):

EMCC (Emergency Medical Care Committee)

SUPERVISORIAL DISTRICT IN WHICH YOU RESIDE: [] First [x] Second [] Third [] Fourth [] Fifth

APPLICANT NAME AND RESIDENCE ADDRESS:

Lawrence A Grihalva
First Name Middle Name Last Name

Street Address City State Zip Code

Home Phone Number Cell Phone Number

Email Address

CURRENT EMPLOYER:

OCCUPATION/JOB TITLE:

BUSINESS ADDRESS:

BUSINESS PHONE NUMBER:

EMPLOYMENT HISTORY: Please attach a resume to this application and provide any information that would be helpful in evaluating your application.

ARE YOU A CITIZEN OF THE UNITED STATES: [x] YES [] NO

IF NO, NAME OF COUNTRY OF CITIZENSHIP:

ARE YOU A REGISTERED VOTER? [x] YES [] NO

IF YES, NAME COUNTY YOU ARE REGISTERED IN: Orange County

LIST ALL CURRENT PROFESSIONAL OR COMMUNITY ORGANIZATIONS AND SOCIETIES OF WHICH YOU ARE A MEMBER.

<u>ORGANIZATION/SOCIETY</u>	<u>FROM (MO./YR.)</u>	<u>TO (MO./YR.)</u>
Not Applicable		

WITHIN THE LAST FIVE YEARS, HAVE YOU BEEN AFFILIATED WITH ANY BUSINESS OR NONPROFIT AGENCY(IES)? YES NO

DO YOU OWN REAL OR PERSONAL PROPERTY OR HAVE FINANCIAL HOLDING WHICH MIGHT PRESENT A POTENTIAL CONFLICT OF INTEREST? YES NO

HAVE YOU BEEN CONVICTED OF A FELONY OR MISDEMEANOR CRIME SINCE YOUR 18TH BIRTHDAY? YOU ARE NOT REQUIRED TO DISCLOSE ANY OF THE FOLLOWING: ARRESTS OR DETENTIONS THAT DID NOT RESULT IN A CONVICTION; CONVICTIONS THAT HAVE BEEN JUDICIALLY DISMISSED, EXPUNGED OR ORDERED SEALED; INFORMATION CONCERNING REFERRAL TO AND PARTICIPATION IN ANY PRETRIAL OR POSTRIAL DIVERSION PROGRAM; AND CERTAIN DRUG RELATED CONVICTIONS THAT ARE OLDER THAN TWO YEARS, AS LISTED IN CALIFORNIA LABOR CODE § 432.8 (INCLUDING VIOLATIONS OF CALIFORNIA HEALTH AND SAFETY CODE SECTIONS 11357(B) AND (C), 11360(C) 11364, 11365 AND 11550 – AS THEY RELATE TO MARIJUANA)?

YES NO

IF YES, PLEASE EXPLAIN AND ATTACH ADDITIONAL SHEETS, IF NECESSARY.

PLEASE BRIEFLY EXPLAIN WHY YOU WISH TO SERVE ON THIS BOARD, COMMITTEE, OR COMMISSION. ATTACH ADDITIONAL SHEETS, IF NECESSARY.

As an Orange County resident since 1971, I care greatly about the integrity and quality of our EMS system.

DATE: April 6, 2021

APPLICANTS SIGNATURE: 

CLERK OF THE BOARD OF SUPERVISORS USE ONLY – DO NOT WRITE BELOW THIS LINE

Date Received: _____	Received by: _____ Deputy Clerk of the Board of Supervisors
Date referred: _____	
To: <input type="checkbox"/> BOS District 1 <input type="checkbox"/> BOS District 2 <input type="checkbox"/> BOS District 3 <input type="checkbox"/> BOS District 4 <input type="checkbox"/> BOS District 5	
<input type="checkbox"/> All BOS <input type="checkbox"/> BCC Contact Person Name _____	

LAWRENCE A. GRIHALVA, J.D., MICP

LICENSURE / CERTIFICATION

- **Attorney at Law** (License #183839) – *State Bar of California*
- **Mobile Intensive Care Paramedic** (License #P08425) – *California EMS Authority*
- **Senior Chaplain** (License #CA50106CS) – *International Fellowship of Chaplains*
- **Emergency Medical Services Educator** (#070633) – *National Association of EMS Educators*
- **Basic Life Support Provider & Instructor** – *American Heart Association*

EDUCATION

- BOSTON COLLEGE LAW SCHOOL** Newton, MA
Juris Doctor Degree: May 1995
Finalist, 1993-1994 Intramural Negotiation Competition
California State Bar: Admitted December 3, 1996
- UNIVERSITY OF CALIFORNIA, LOS ANGELES** Los Angeles, CA
Bachelor of Arts Degree, History Major: June 1987
- DANIEL FREEMAN PARAMEDIC SCHOOL** Inglewood, CA
Graduated 2nd in class with a 95.5% GPA: August 1989

EXPERIENCE

- SADDLEBACK COLLEGE** Mission Viejo, CA
Professor of Emergency Medical Services & Health Information Technology August 2011 - Present
- Full-time faculty professor for EMT, paramedic, and HIT programs. Primary duty as EMT Program Director: Responsible for all aspects of managing the EMT education program that prepares students to become certified Emergency Medical Technicians, including lectures, skills practice and testing, clinical Internships, evaluation, and curriculum development. Also teach biochemistry, pathophysiology, and legal aspects for the paramedic program, as well as teaching the Paramedic Preparatory Course (EMT 219). Served as HIT Program Coordinator January 2013 to January 2015: Assisted HIT Program Director with CAHIIM accreditation process, including successfully advocating for an HIT department separate from the MA program, and managing Directed Practice / Professional Practical Experience Program.
- COSTA MESA FIRE DEPARTMENT** Costa Mesa, CA
Emergency Medical Services Coordinator July 2001 - July 2011, March 2017 - Present
- Manage all aspects of prehospital emergency medical care provided by ~26 Firefighter-Paramedics and ~58 Firefighter-Emergency Medical Technicians, including: Health records management; HIPAA compliance; Continuing education and training; Protocol development; Equipment and supplies; Disease prevention / infection control; Ambulance oversight; Patient billing; Quality assurance and improvement; EMS budget; Conflict resolution; 911 abuse mitigation; Contract writing. Provide medical advice and support for Police Department and Communications Department personnel. Serve as city resource for all public health and safety matters. Represent city on local and state EMS committees and task forces. Planned, implemented, and coordinated a city-wide Public Access Defibrillation program. Developed a Refusal Against Medical Advice form and policy that was adopted by all county fire departments. Led the creation of the legally accepted definition of "patient" that was adopted by all county fire departments and the Orange County EMS Agency as part of its official county-wide EMS protocols.

ULTIMATE MEDICAL ACADEMY
Online Adjunct Instructor

Tampa, FL
June 2015 - May 2017

Part-time online instructor responsible for teaching and managing multiple classes simultaneously, including HS2305 "Legal & Ethical Issues in Human Services" and ME1410 "Medical Law, Ethics, & Records Management."

LECTURER ON LEGAL & ETHICAL ASPECTS OF PREHOSPITAL CARE
Guest Speaker

Los Angeles & Orange Counties
February 1996 - Present

Conduct presentations for fire departments, ambulance companies, base station hospitals, and paramedic/EMT training programs on various prehospital care subjects, with a focus on legal and ethical aspects. Legal topics include state organization of EMS and the legal authority for prehospital care, negligence theory, governmental and provider immunities, patient autonomy issues, mandatory reporter situations, emergency driving, off-duty duty to act situations, documentation, and minimizing liability. Non-legal topics include: Airway Management, Cardiac Arrest Management, EKG, and Prehospital Crisis Intervention. Lectures conducted for:

- ❖ AMERICAN MEDICAL RESPONSE
- ❖ ANAHEIM MEMORIAL MEDICAL CENTER
- ❖ CEDARS-SINAI MEDICAL CENTER
- ❖ CERRITOS COLLEGE ROP
- ❖ CALIFORNIA PARAMEDIC INSTITUTE
- ❖ CULVER CITY FIRE DEPARTMENT
- ❖ DANIEL FREEMAN PARAMEDIC SCHOOL
- ❖ EMS ENSENADA CRUISE 1997
- ❖ HOAG MEMORIAL HOSPITAL
- ❖ HUNTINGTON BEACH MEDICAL CENTER
- ❖ LOS ANGELES CITY FIRE DEPARTMENT
- ❖ LA COUNTY PARAMEDIC TRAINING INSTITUTE
- ❖ MISSION HOSPITAL REGIONAL MEDICAL CTR.
- ❖ SADDLEBACK COLLEGE PARAMEDIC SCHOOL
- ❖ ST. JUDE MEDICAL CENTER
- ❖ UCLA CENTER FOR PREHOSPITAL CARE
- ❖ UCLA PARAMEDIC SCHOOL
- ❖ WESTERN MEDICAL CENTER SANTA ANA

CALIFORNIA STATE FIREFIGHTERS ASSOCIATION
Emergency Medical Services Committee Chairman

Sacramento, CA
April 2008 - April 2011

Served as expert advisor regarding all EMS-related matters for one of the state's three main Fire Service advocacy groups. Analyzed and wrote opinions on proposed legislation and regulations that affect the Fire Service, Emergency Medical Services, and/or the public health and safety. Represented the Fire Service on state task forces.

SADDLEBACK COLLEGE
Associate Faculty, EMS Educator

Mission Viejo, CA
September 1999 - June 2003

Coordinated and provided instruction for Emergency Medical Technician course, including all aspects of Basic Life Support level prehospital care, including anatomy, physiology, pathophysiology, and clinical skills.

AMERICAN HEART ASSOCIATION
Senior Director, Operation Heartbeat

Los Angeles, CA
October 1999 - June 2001

Responsible for developing, implementing, and coordinating all American Heart Association acute event programs designed to decrease deaths from heart attack and sudden cardiac arrest in the Western States Affiliate (California, Nevada, Utah). Activities included: Conducting community need assessments; Increasing awareness of signs and symptoms of heart attack and the importance of calling 911 immediately; Increasing the number of people trained in CPR; Promoting Public Access Defibrillation (PAD) programs in strategic locations; Advocating for hospital and prehospital utilization of American Heart Association Emergency Cardiovascular Care guidelines.

UCI MEDICAL CENTER / BEVERLY HOSPITAL / L.A. FIRE DEPARTMENT
American Heart Association Regional Faculty Advisor

Los Angeles & Orange Counties
July 1999 - December 2002

Served as an American Heart Association volunteer advisor to these Orange and Los Angeles county agencies. Assisted and guided Training Center Coordinators in the planning and implementation of Advanced Cardiac Life Support, Pediatric Advanced Life Support, Basic Life Support, and Heartsaver AED Provider courses. Conducted instructor courses for provider-level personnel. Ensured compliance with American Heart Association regulations and Emergency Cardiovascular Care guidelines.

DANIEL FREEMAN PARAMEDIC SCHOOL
Faculty Education Specialist

Inglewood, CA
January 1996 - January 1999

Planned, implemented, and co-managed all phases of paramedic education and training. Full management responsibilities for 25 paramedic and nurse skills instructors including selection, evaluation, and termination. Wrote admissions and testing policies, and advised Program Director on revision of policy manual including student termination process. Lectures included all aspects of prehospital care including: Cardiac patient and arrest management; Pediatrics; Legal aspects and documentation; Local protocols; Traumatic emergencies; Medical emergencies; Anatomy; Physiology; Pathophysiology. Represented school at local and state Emergency Medical Services Authority meetings and at conflict resolution meetings with preceptor agencies.

RIVERSIDE COUNTY DISTRICT ATTORNEY'S OFFICE
Certified Law Clerk

Riverside, CA
May - July 1994

Represented the People of California at preliminary hearings, felony settlement conferences, sentencing proceedings, and plea negotiations. Duties included case preparation and presentation, and legal research and writing. Prepared two jury trials and one court trial.

LOS ANGELES CITY FIRE DEPARTMENT
Paramedic

Los Angeles, CA
January 1989 - October 1992

Responsible for the treatment and transport of the critically ill and injured. Directed fire and law enforcement personnel during multi-casualty operations. Served as a preceptor for two paramedic interns.

UCI MEDICAL CENTER
Senior Emergency Trauma Technician

Orange, CA
February - December 1988

Assisted emergency department physicians and nurses in patient assessment and treatment. Responsibilities included triage, physical examination, charting, and the operation of various diagnostic devices (e.g., 12-Lead EKG, pulse oximeter).

UCLA EMERGENCY MEDICAL SERVICES
Station Officer / Emergency Medical Technician

Los Angeles, CA
January 1986 - December 1987

Served on primary responder BLS ambulance providing emergency medical care and transport for the UCLA community and West Los Angeles area. Worked closely with LAFD paramedics. Assisted advanced medical team with critical pediatric/neonatal transports. Interviewed crime victims and prepared police reports.

MISCELLANEOUS EDUCATION & TRAINING

- Introduction to Community Emergency Response Team Program IS-317 *May 2011*
- Terrorism Liaison Officer, Intermediate Course (OCIAC / JRIC) *January 2010*
- Terrorism Liaison Officer, Basic Course (OCIAC / JRIC) *December 2008*
- Statewide Golden Guardian Exercise *November 2008*
- Emergency Operations Center Orientation G611Or (Costa Mesa) *November 2008*
- DiSC Management Styles & Behavior Workshop 360 *June 2008*
- Leadership Academy Course 105: Project Management (California Fire Chiefs Association) *April 2008*
- Standardized Emergency Management System G606 (Costa Mesa Fire Department) *August 2006*
- National Incident Management System IS-700 (Costa Mesa Fire Department) *August 2006*
- Incident Command System I-100 (Costa Mesa Fire Department) *August 2006*
- Lethal Force Institute, LFI-I (Instructor Massad Ayoob, Wallingford, CT) *October 2005*
- Pediatric Education Prehospital Professionals ALS Coordinator Course (Mission Hospital) *September 2005*
- Tactical Medic Course (Medic Up: Riverside, CA) *February 2004*
- Pediatric Education for Prehospital Professionals Course (Mission Hospital) *September 2003*
- Emergency Medical Dispatcher Certification Course (NAEMD Cert. #101270) *July 2002*
- Air Ambulance Flight Physiology (Mercy Air) *November 2001*
- Pediatric Education for Paramedics Instructor Course (Saddleback College) *May 1997*

CRISIS INTERVENTION TRAINING

- Advanced Group Crisis Intervention (Orange County Department of Education) *April 2014*
- Emotional & Spiritual Care in Disasters (Salvation Army) *April 2014*
- Pastoral Crisis Intervention, ICISF (Living Shield Ministries) *May 2011*
- Grief Following Trauma, ICISF (Living Shield Ministries) *April 2011*
- Practical Chaplaincy Certification Course, National Center for Chaplain Development *February 2011*
- Suicide Prevention, Intervention, and Postvention, ICISF (NCCD) *November 2010*
- Group Crisis Intervention, ICISF (NCCD) *October 2010*
- Individual Crisis Intervention & Peer Support, ICISF (NCCD) *October 2010*
- Basic Chaplain Certification Course, International Fellowship of Chaplains *September 2010*
- Hope Force International Reservist Basic Training *February 2010*

RECOGNITION

- ❖ **Team Member of the Year Award**
Costa Mesa Fire & Rescue Department *December 2019*
- ❖ **Team Member of the Month Award**
Costa Mesa Fire & Rescue Department *October 2019*
- ❖ **Educator Recognition Award**
University of California Irvine, Division of Undergraduate Education *May 2014*
- ❖ **Meritorious Service Award**
Orange County Emergency Medical Services Agency *July 2010*
- ❖ **Employee of the Month**
City of Costa Mesa *July 2010*
- ❖ **Emergency Medical Services Award**
National Society of the Sons of the American Revolution *April 2009*
- ❖ **Individual Accomplishment Award for Public Service**
Federal Executive Board, Greater Los Angeles Area *May 2009*
- ❖ **Servant of Youth Award**
Boys Scouts of America, Orange County Council *June 2008*
- ❖ **Overachiever Award**
Orange County Fire Services Association *October 2006*
- ❖ **Fire Service Professional of the Year 2005**
American Legion, Newport Harbor Post 291 *April 2005*



MEMORANDUM

To: Board of Supervisors

From: Katrina Foley

Date: April 12, 2021

CC: Office of the Clerk of the Board

Frank Kim, Chief Executive Officer

RE: Additional background information on 2nd District's supplemental agenda items for appointments to various boards, commissions and committees:

S43B – Appointment of Alexander Gonzalez of Costa Mesa to the Orange County Veterans Advisory Council is for a two year term ending 1/2/23 and replaces the expired term held by David Han.

S43C – Appointment of Michael Wellborn of Huntington Beach to the Orange County Parks Commission is for a term concurrent with the 2nd District Supervisor's term of office and replaces the expired term held by Michael Posey.

S43D – Appointment of Ada Briceño of Stanton to the Orange County Human Relations Commission is for a two year term that begins on date of appointment, 4/13/21 – 4/12/23, and replaces the expired term held by Michael Reynolds.

S43E – Appointment of Muriel Ullman of Newport Beach to the Housing and Community Development Commission is to complete the existing two year term that ends 6/30/21 and replaces the expired term held by James Fisler.

S43F – Appointment of David Lee of Corona Del Mar to the John Wayne Airport Arts Commission is for a term concurrent with the 2nd District Supervisor's term of office and replaces the expired term held by Stephanie Ann Bachiero.

S43G – Appointment of Lawrence Grihalva to the Emergency Medical Care Committee is to complete the existing two year term that ends 6/30/21 and replaces the expired term held by Jeffrey Barke.

S43H – Appointment of Rev. Rayna Hamre to the Community Action Partnership of Orange County is for a term concurrent with the 2nd District Supervisor's term off office and replaces the expired term held by Nimusha Punnen Jacob.

S43I – Appointment of Susan Dvorak to the Orange County Airport Commission is for a term concurrent with the 2nd District Supervisor's term of office and replaces the vacant position previously held by Lee Lowrey.



5434

MEMORANDUM

To: Clerk of the Board

From: Katrina Foley

Date: April 7, 2021

RE: Appointment of Rev. Rayna Hamre to the Community Action Partnership of Orange County

I would like to appoint Rev. Rayna Hamre to the Community Action Partnership of Orange County.

Please place this item on the 4/13/21 agenda.

RECEIVED
CLERK OF THE BOARD

APR 07 2021



APPLICATION FOR COUNTY OF ORANGE
BOARD, COMMISSION OR COMMITTEE

(FOR COUNTY USE ONLY)

Return to:
Clerk of the Board of Supervisors
333 West Santa Ana Blvd., Suite 465
Santa Ana, California 92701
Website: www.ocgov.com/gov/cob/

Instructions: Please complete each section below. Be sure to enter the title of the Board, Commission or Committee for which you desire consideration. For information or assistance, please contact the Clerk of the Board of Supervisor's Office at (714) 834-2206. Please print in ink or type.

**NAME OF BOARD, COMMISSION, OR COMMITTEE TO WHICH YOU ARE APPLYING FOR MEMBERSHIP
(SEE LIST AT [HTTP://WWW.OCGOV.COM/GOV/COB/BCC/CONTACT](http://www.ocgov.com/gov/cob/bcc/contact)):**

Commission on Homelessness

SUPERVISORIAL DISTRICT IN WHICH YOU RESIDE: First Second Third Fourth Fifth

APPLICANT NAME AND RESIDENCE ADDRESS:

Rayna **C** **Hamre**
First Name Middle Name Last Name

Street Address City State Zip Code

Home Phone Number Cell Phone Number

Email Address

CURRENT EMPLOYER:

OCCUPATION/JOB TITLE:

BUSINESS ADDRESS:

BUSINESS PHONE NUMBER:

EMPLOYMENT HISTORY: Please attach a resume to this application and provide any information that would be helpful in evaluating your application.

ARE YOU A CITIZEN OF THE UNITED STATES: YES NO

IF NO, NAME OF COUNTRY OF CITIZENSHIP:

ARE YOU A REGISTERED VOTER? YES NO
IF YES, NAME COUNTY YOU ARE REGISTERED IN: Orange County, CA

LIST ALL CURRENT PROFESSIONAL OR COMMUNITY ORGANIZATIONS AND SOCIETIES OF WHICH YOU ARE A MEMBER.

ORGANIZATION/SOCIETY	FROM (MO./YR.)	TO (MO./YR.)
Greater Huntington Beach Interfaith Council	3/2021	Present
Clergy and Laity United for Economic Justice OC	11/2016	Present
UU Ministerial Association (UUMA)	6/2016	Present

WITHIN THE LAST FIVE YEARS, HAVE YOU BEEN AFFILIATED WITH ANY BUSINESS OR NONPROFIT AGENCY(IES)? YES NO

DO YOU OWN REAL OR PERSONAL PROPERTY OR HAVE FINANCIAL HOLDING WHICH MIGHT PRESENT A POTENTIAL CONFLICT OF INTEREST? YES NO

HAVE YOU BEEN CONVICTED OF A FELONY OR MISDEMEANOR CRIME SINCE YOUR 18TH BIRTHDAY? YOU ARE NOT REQUIRED TO DISCLOSE ANY OF THE FOLLOWING: ARRESTS OR DETENTIONS THAT DID NOT RESULT IN A CONVICTION; CONVICTIONS THAT HAVE BEEN JUDICIALLY DISMISSED, EXPUNGED OR ORDERED SEALED; INFORMATION CONCERNING REFERRAL TO AND PARTICIPATION IN ANY PRETRIAL OR POSTTRIAL DIVERSION PROGRAM; AND CERTAIN DRUG RELATED CONVICTIONS THAT ARE OLDER THAN TWO YEARS, AS LISTED IN CALIFORNIA LABOR CODE § 432.8 (INCLUDING VIOLATIONS OF CALIFORNIA HEALTH AND SAFETY CODE SECTIONS 11357(B) AND (C), 11360(C) 11364, 11365 AND 11550 – AS THEY RELATE TO MARIJUANA)?

YES NO

IF YES, PLEASE EXPLAIN AND ATTACH ADDITIONAL SHEETS, IF NECESSARY.

PLEASE BRIEFLY EXPLAIN WHY YOU WISH TO SERVE ON THIS BOARD, COMMITTEE, OR COMMISSION. ATTACH ADDITIONAL SHEETS, IF NECESSARY.

Serving on the Commission on Homelessness would allow me to better serve my community on the issue of homelessness.

DATE: 4/7/2021

APPLICANTS SIGNATURE: *Rayna C. Hamre*

CLERK OF THE BOARD OF SUPERVISORS USE ONLY – DO NOT WRITE BELOW THIS LINE

Date Received: _____ Received by: _____

Date referred: _____

Deputy Clerk of the Board of Supervisors

To: BOS District 1 BOS District 2 BOS District 3 BOS District 4 BOS District 5
 All BOS BCC Contact Person Name _____

Employment and Unitarian Universalist Experience

Affiliated Community Minister

Tapestry Unitarian Universalist Congregation, Lake Forest, CA **2019-Present**

Founding Member of Welcoming Neighbors Home advocacy group, provide worship services, memorial services for those experiencing homelessness, teach adults and children. Founder and Lead Teacher for an intensive meditation program, serving in Orange County.

Membership Coordinator

Unitarian Universalist Church of Long Beach **June 2018-2020**

Work with Membership Committee and Minister to collaboratively design and coordinate a membership welcome and integration strategy. Provide a point of contact and be a pastoral guide throughout the initial entry into the church. Connect visitors and new members to church programs. Help church programs open their ministries to the presence and gifts of newcomers. Help members and friends discern their passions, talents, and leadership qualities and encourage their integration into church life and service to the church. Act as a resource for committees and staff communicating the gifts and interests of members and friends. Create annual calendar of membership ministry events and publicize. Create and update materials that communicate church programs of interest to newcomers. Celebrate new members and introduce them to the congregation through worship, social events, newsletter and other media. Manage professional expense account.

Intern at the Unitarian Universalist Church in Anaheim (UUCA) and Boys and Girls Club of Anaheim

September 2016-June 2018

At UUCA presented social justice sermons monthly and taught adult religious education classes. Attended Board of Directors and Worship Committee planning meetings, and UUCA events under the supervision of and in collaboration with the senior minister and the Ministerial Internship Committee. Through the Meadville Lombard Theological School Master of Divinity program, volunteered at the Boys and Girls Club in Anaheim after school program for low-income and 'motel' kids. Supervised the library where children completed homework, read, and socialized; provided a safe after school space with pastoral listening and support.

Director of Religious Education

Orange Coast Unitarian Universalist Church, Costa Mesa, CA **August 2010-May 2016**

Oversaw the Religious Education program for children and teenagers. Recruited volunteers, scheduled and organized classes for a church of 150+ members. Coordinated Our Whole Lives sex education classes. Taught RE classes to preschoolers through adult ages; trained volunteers. Managed a budget; evaluated, selected and purchased curricula and classroom supplies. Traveled for denominational and district training and relayed information to congregants. Actively participated in LREDA UU professional organization for religious educators. Hired and supervised OCUUC's Sunday caregiver staff in collaboration with the RE Committee. Worked in a collegial manner with clergy, staff, volunteers and interfaith contacts. Encouraged and nurtured young people and families. Regularly updated the RE and DRE blog.

- Administrative: Used PowerChurch database for RE tracking. Scheduled volunteers and caregivers, prepared timesheets for payroll. Managed the RE budget. Created materials for classes and distribution.
- Rites of Passage Facilitator: Led and co-led child dedications, bridging ceremonies, as well as teacher dedication and appreciation ceremonies during OCUUC services.
- Liaison: Social justice projects with Share Ourselves Orange County.

Rev. Rayna Hamre

- President: Liberal Religious Educators Association, Pacific Southwest District, 2012-2014.
- Facilitator: Our Whole Lives sexuality and life education. Coordinator for OCUUC classes, 2010-15.
- Participant: Faithful Fools program. Trained in San Francisco and coordinated a trip for UU youth to the Tenderloin District to educate by experience on homeless issues. San Francisco, Spring 2011.

Lay Leadership at OCUUC - Highlights

- Member: since 1989. Active lay leader, 1989 through August 2010, when I accepted the DRE position.
- Youth Advisor: RE Teacher and leader, served for over 20 years as a regular OCUUC teacher and substitute in all class levels. Led services for children and youth worship. Recipient of OCUUC Joan Gillan RE Award, 2004.
- Member: OCUUC Board of Directors, OCUUC, 2004-2005. Chair and Member: Adult Worship Committee, 2004-2010. Secretary: OCUUC AIDS Team Ministry Board, 2001.
- Delegate and Attendee Unitarian Universalist General Assembly: attendee Portland, 2015; attendee Phoenix 2012; delegate Charlotte, NC 2011; attendee Minneapolis, 2010; delegate Salt Lake City 2009; attendee Long Beach California 2006; attendee Arizona, 1997.
- Ritual Facilitator, Narrator, Creator and Leader: Winter Solstice Singing Ritual 2006-2008, 2017 (narrator), singer 2013 and CUUPS rituals and services 1996-2009. Author and worship leader for OCUUC Summer Solstice Ritual 2008 and '09. Chair and Founding Member: Covenant of UU Pagans, 1995-2010.
- Facilitator: OCUUC Covenant Groups, 1999-2003.
- Planning Committee Member: Orange County Religious Diversity Forum. Hosted at UC Irvine. Volunteer Coordinator for the 2003 Forum. UC Irvine, Orange County, CA, May 2003-2004. Attendee: Parliament of the World's Religions, Barcelona, Spain, July 2004.

**Library Media Assistant, Paul Revere Elementary School
Anaheim City School District, Anaheim**

October 2006-June 2010

**Administrative Assistant III, Condensed Matter Group, Physics and Astronomy Department
University of California, Irvine**

January 2006-September 2006

**Library Assistant V/Office Manager, Reference Department, Science Library and Langson Library
University of California, Irvine**

June 2001-December 2005

**Library Assistant III, Reference, and Interlibrary Loan Departments, Science and Langson Libraries
University of California, Irvine**

1993 – 2001

Instructor, Golden West College, Huntington Beach, CA

1992-1994

Education

- Master of Divinity Degree, Meadville Lombard Theological School, Chicago, IL. May, 2018.
<http://www.meadville.edu/our-programs/master-of-divinity/>. Ordained February 2019.
- Clinical Pastoral Education (CPE). St. Joseph's Hospital, Orange, CA, Summer Intensive 2014. One CPE unit which included 100 hours of instruction and 300 clinical hours. Worked with diverse patients and families who were in medical crisis situations.
- Master of Arts Degree, History, California State University, Fullerton. Teaching Assistantship.
- Bachelor of Arts Degree, Classical Civilizations, University of California, Irvine.
- AA Degree, Golden West College, Huntington Beach, CA.

Membership in Professional and Community Organizations

- Greater Huntington Beach Interfaith Council
- UU Ministerial Association (UUMA)
- UU Service Committee (UUSC)
- UU PSW White Scholarship Committee
- Clergy and Laity United for Economic Justice Orange County (CLUE)
- The C. G. Jung Club of Orange County



MEMORANDUM

To: Board of Supervisors

From: Katrina Foley

Date: April 12, 2021

CC: Office of the Clerk of the Board
Frank Kim, Chief Executive Officer

RE: Additional background information on 2nd District's supplemental agenda items for appointments to various boards, commissions and committees:

S43B – Appointment of Alexander Gonzalez of Costa Mesa to the Orange County Veterans Advisory Council is for a two year term ending 1/2/23 and replaces the expired term held by David Han.

S43C – Appointment of Michael Wellborn of Huntington Beach to the Orange County Parks Commission is for a term concurrent with the 2nd District Supervisor's term of office and replaces the expired term held by Michael Posey.

S43D – Appointment of Ada Briceño of Stanton to the Orange County Human Relations Commission is for a two year term that begins on date of appointment, 4/13/21 – 4/12/23, and replaces the expired term held by Michael Reynolds.

S43E – Appointment of Muriel Ullman of Newport Beach to the Housing and Community Development Commission is to complete the existing two year term that ends 6/30/21 and replaces the expired term held by James Fisler.

S43F – Appointment of David Lee of Corona Del Mar to the John Wayne Airport Arts Commission is for a term concurrent with the 2nd District Supervisor's term of office and replaces the expired term held by Stephanie Ann Bachiero.

S43G – Appointment of Lawrence Grihalva to the Emergency Medical Care Committee is to complete the existing two year term that ends 6/30/21 and replaces the expired term held by Jeffrey Barke.

S43H – Appointment of Rev. Rayna Hamre to the Community Action Partnership of Orange County is for a term concurrent with the 2nd District Supervisor's term off office and replaces the expired term held by Nimusha Punnen Jacob.

S43I – Appointment of Susan Dvorak to the Orange County Airport Commission is for a term concurrent with the 2nd District Supervisor's term of office and replaces the vacant position previously held by Lee Lowrey.

Bd. 4/13/21, Item S43H

Revised Application attached



APPLICATION FOR COUNTY OF ORANGE BOARD, COMMISSION OR COMMITTEE

(FOR COUNTY USE ONLY)

Return to:

Clerk of the Board of Supervisors
333 West Santa Ana Blvd., Suite 465
Santa Ana, California 92701
Website: www.ocgov.com/gov/cob/

Instructions: Please complete each section below. Be sure to enter the title of the Board, Commission or Committee for which you desire consideration. For information or assistance, please contact the Clerk of the Board of Supervisor's Office at (714) 834-2206. Please print in ink or type.

NAME OF BOARD, COMMISSION, OR COMMITTEE TO WHICH YOU ARE APPLYING FOR MEMBERSHIP (SEE LIST AT HTTP://WWW.OCGOV.COM/GOV/COB/BCC/CONTACT):

Community Action Partnership of Orange County

SUPERVISORIAL DISTRICT IN WHICH YOU RESIDE: [] First [x] Second [] Third [] Fourth [] Fifth

APPLICANT NAME AND RESIDENCE ADDRESS:

Rayna Clare Hamre
First Name Middle Name Last Name

Street Address City State Zip Code

Home Phone Number Cell Phone Number

Email Address

CURRENT EMPLOYER:

OCCUPATION/JOB TITLE:

BUSINESS ADDRESS:

BUSINESS PHONE NUMBER:

EMPLOYMENT HISTORY: Please attach a resume to this application and provide any information that would be helpful in evaluating your application.

ARE YOU A CITIZEN OF THE UNITED STATES: [x] YES [] NO

IF NO, NAME OF COUNTRY OF CITIZENSHIP:

ARE YOU A REGISTERED VOTER? [x] YES [] NO

IF YES, NAME COUNTY YOU ARE REGISTERED IN: Orange County, CA

LIST ALL CURRENT PROFESSIONAL OR COMMUNITY ORGANIZATIONS AND SOCIETIES OF WHICH YOU ARE A MEMBER.

ORGANIZATION/SOCIETY	FROM (MO./YR.)	TO (MO./YR.)
Greater Huntington Beach Interfaith Council	3/2021	Present
Clergy and Laity United for Economic Justice OC	11/2016	Present
UU Ministerial Association (UUMA)	6/2016	Present

WITHIN THE LAST FIVE YEARS, HAVE YOU BEEN AFFILIATED WITH ANY BUSINESS OR NONPROFIT AGENCY(IES)? YES NO

DO YOU OWN REAL OR PERSONAL PROPERTY OR HAVE FINANCIAL HOLDING WHICH MIGHT PRESENT A POTENTIAL CONFLICT OF INTEREST? YES NO

HAVE YOU BEEN CONVICTED OF A FELONY OR MISDEMEANOR CRIME SINCE YOUR 18TH BIRTHDAY? YOU ARE NOT REQUIRED TO DISCLOSE ANY OF THE FOLLOWING: ARRESTS OR DETENTIONS THAT DID NOT RESULT IN A CONVICTION; CONVICTIONS THAT HAVE BEEN JUDICIALLY DISMISSED, EXPUNGED OR ORDERED SEALED; INFORMATION CONCERNING REFERRAL TO AND PARTICIPATION IN ANY PRETRIAL OR POSTTRIAL DIVERSION PROGRAM; AND CERTAIN DRUG RELATED CONVICTIONS THAT ARE OLDER THAN TWO YEARS, AS LISTED IN CALIFORNIA LABOR CODE § 432.8 (INCLUDING VIOLATIONS OF CALIFORNIA HEALTH AND SAFETY CODE SECTIONS 11357(B) AND (C), 11360(C) 11364, 11365 AND 11550 - AS THEY RELATE TO MARIJUANA)?

YES NO

IF YES, PLEASE EXPLAIN AND ATTACH ADDITIONAL SHEETS, IF NECESSARY.

PLEASE BRIEFLY EXPLAIN WHY YOU WISH TO SERVE ON THIS BOARD, COMMITTEE, OR COMMISSION. ATTACH ADDITIONAL SHEETS, IF NECESSARY.

Serving on the Commission on Homelessness would allow me to better serve my community on the issue of homelessness.

DATE: 4/7/2021

APPLICANTS SIGNATURE: Rayna C. Hamel

CLERK OF THE BOARD OF SUPERVISORS USE ONLY - DO NOT WRITE BELOW THIS LINE

Date Received: _____	Received by: _____ Deputy Clerk of the Board of Supervisors			
Date referred: _____				
To: <input type="checkbox"/> BOS District 1	<input type="checkbox"/> BOS District 2	<input type="checkbox"/> BOS District 3	<input type="checkbox"/> BOS District 4	<input type="checkbox"/> BOS District 5
<input type="checkbox"/> All BOS	<input type="checkbox"/> BCC Contact Person Name _____			



543I

MEMORANDUM

To: Clerk of the Board

From: Katrina Foley 

Date: April 7, 2021

RE: Appointment of Susan Dvorak to the Orange County Airport Commission

I would like to appoint Susan Dvorak to the Orange County Airport Commission.

Please place this item on the 4/13/21 agenda.

RECEIVED
CLERK OF THE BOARD

APR 07 2021



APPLICATION FOR COUNTY OF ORANGE
BOARD, COMMISSION OR COMMITTEE

(FOR COUNTY USE ONLY)

Return to:
Clerk of the Board of Supervisors
333 West Santa Ana Blvd., Suite 465
Santa Ana, California 92701
Website: www.ocgov.com/gov/cob/

Instructions: Please complete each section below. Be sure to enter the title of the Board, Commission or Committee for which you desire consideration. For information or assistance, please contact the Clerk of the Board of Supervisor's Office at (714) 834-2206. Please print in ink or type.

**NAME OF BOARD, COMMISSION, OR COMMITTEE TO WHICH YOU ARE APPLYING FOR MEMBERSHIP
(SEE LIST AT [HTTP://WWW.OCGOV.COM/GOV/COB/BCC/CONTACT](http://WWW.OCGOV.COM/GOV/COB/BCC/CONTACT)):**

Orange County Airport Commission

SUPERVISORIAL DISTRICT IN WHICH YOU RESIDE: First Second Third Fourth Fifth

APPLICANT NAME AND RESIDENCE ADDRESS:

Susan

Dvorak

First Name

Middle Name

Last Name

Street Address

City

State

Zip Code

Home Phone Number

Cell Phone Number

Email Address

CURRENT EMPLOYER: N/A

OCCUPATION/JOB TITLE: _____

BUSINESS ADDRESS: _____

BUSINESS PHONE NUMBER: _____

EMPLOYMENT HISTORY: Please attach a resume to this application and provide any information that would be helpful in evaluating your application.

ARE YOU A CITIZEN OF THE UNITED STATES: YES NO

IF NO, NAME OF COUNTRY OF CITIZENSHIP: _____

ARE YOU A REGISTERED VOTER? YES NO

IF YES, NAME COUNTY YOU ARE REGISTERED IN: Orange County

LIST ALL CURRENT PROFESSIONAL OR COMMUNITY ORGANIZATIONS AND SOCIETIES OF WHICH YOU ARE A MEMBER.

<u>ORGANIZATION/SOCIETY</u>	<u>FROM (MO./YR.)</u>	<u>TO (MO./YR.)</u>
<u>AirFair</u>	<u>2019</u>	<u>present</u>
<u>City of Newport Beach Aviation Cmte</u>	<u>2020</u>	<u>present</u>
<u>SPON (Stop Polluting Our Newport)</u>	<u>2021</u>	<u>present</u>

WITHIN THE LAST FIVE YEARS, HAVE YOU BEEN AFFILIATED WITH ANY BUSINESS OR NONPROFIT AGENCY(IES)? YES NO

DO YOU OWN REAL OR PERSONAL PROPERTY OR HAVE FINANCIAL HOLDING WHICH MIGHT PRESENT A POTENTIAL CONFLICT OF INTEREST? YES NO

HAVE YOU BEEN CONVICTED OF A FELONY OR MISDEMEANOR CRIME SINCE YOUR 18TH BIRTHDAY? YOU ARE NOT REQUIRED TO DISCLOSE ANY OF THE FOLLOWING: ARRESTS OR DETENTIONS THAT DID NOT RESULT IN A CONVICTION; CONVICTIONS THAT HAVE BEEN JUDICIALLY DISMISSED, EXPUNGED OR ORDERED SEALED; INFORMATION CONCERNING REFERRAL TO AND PARTICIPATION IN ANY PRETRIAL OR POSTTRIAL DIVERSION PROGRAM; AND CERTAIN DRUG RELATED CONVICTIONS THAT ARE OLDER THAN TWO YEARS, AS LISTED IN CALIFORNIA LABOR CODE § 432.8 (INCLUDING VIOLATIONS OF CALIFORNIA HEALTH AND SAFETY CODE SECTIONS 11357(B) AND (C), 11360(C) 11364, 11365 AND 11550 – AS THEY RELATE TO MARIJUANA)?

YES NO

IF YES, PLEASE EXPLAIN AND ATTACH ADDITIONAL SHEETS, IF NECESSARY.

PLEASE BRIEFLY EXPLAIN WHY YOU WISH TO SERVE ON THIS BOARD, COMMITTEE, OR COMMISSION. ATTACH ADDITIONAL SHEETS, IF NECESSARY.

Attached

DATE: 4/7/2021

APPLICANTS SIGNATURE: *Susan Choral*

CLERK OF THE BOARD OF SUPERVISORS USE ONLY – DO NOT WRITE BELOW THIS LINE

Date Received: _____	Received by: _____ Deputy Clerk of the Board of Supervisors			
Date referred: _____				
To: <input type="checkbox"/> BOS District 1	<input type="checkbox"/> BOS District 2	<input type="checkbox"/> BOS District 3	<input type="checkbox"/> BOS District 4	<input type="checkbox"/> BOS District 5
<input type="checkbox"/> All BOS	<input type="checkbox"/> BCC Contact Person Name _____			

Susan Dvorak

Summary of Qualifications

A marketing and public relations professional with a proven track record of creating successful communication and publicity strategies and fundraising events for non-profit organizations.

Professional Accomplishments

- Managed publicity for the Cincinnati Flower Show; executed target marketing strategy; interfaced with local, regional and national television, radio and print media; generated press releases and press kits; implemented interactive promotional events resulting in a 20% increase in attendance.
- Created community awareness event for Ozone House Youth & Family Services in collaboration with NPR, University of Michigan, social service and governmental agencies; partnered with documentary filmmakers, local PBS affiliate to host prescreening of documentary film, The Homestretch, and discussion panel; created pre- and post-screening graphics; created and distributed publicity kits resulting in sold-out event.

Work Experience

Communications Manager, Ozone House Youth & Family Services 2011-2016

- Managed external communications, including press releases, tv, radio, print & social media, collateral marketing materials, and presentations for community education
- Hosted prescreening of documentary film and discussion panel in collaboration with NPR, University of Michigan, social service & governmental agencies
- Managed donor communications including holiday donor appeal marketing materials for database of 5,000 donors resulting in a \$23,000 increase in donations over 2011
- Managed various fundraising events including Harvest of Hope annual fundraiser increasing revenue by 108% from 2011-2014; planned and executed silent auction, invitations, vendor contracts, advertising/public relations and day-of-event coordination
- Created speakers' bureau comprised of former Ozone House youth, board members, development and executive director to speak at community groups and fundraisers
- Implemented Millennial board to engage young adults in educating the community about youth homelessness issues

Project Manager, American College of Trial Lawyers 2008-2010

- Worked closely with ACTL Executive team to complete projects
- Managed appointment process of 700+ College Fellows & enabled them to carry out their assignments
- Acted as College contact for issues pertaining to General, State and Province Committees
- Managed College-sponsored Moot Court Competitions consisting of 300+ teams
- Created briefs for the President's state meetings
- Maintained records for the College's foundation

Writer, Living Magazines 2005-2006

- Researched and wrote community oriented articles for monthly magazine distributed throughout Cincinnati

Publicity Manager, Cincinnati Horticultural Society 2002-2004

- Managed publicity for the Cincinnati Flower Show & Cincinnati Flower & Farm Fest; executed target marketing strategy; interfaced with local, regional & national television, radio & print media; generated press releases and press kits; implemented interactive promotional events; and oversaw creation of collateral materials.
- Grew marketing program resulting in 20% increase in attendance at the Flower Show.
- Publicity efforts resulted in national media coverage including: CNN, Wall Street Journal, Better Homes & Gardens Magazine, Delta Sky Magazine, Country Living Magazine.
- Established extensive network of beneficial community contacts including: Cincinnati Art Museum, Children's Theater of Cincinnati, Cincinnati Museum Center, Taft Museum of Art, Newport on the Levee, Newport Aquarium, and Cincinnati Convention and Visitors Bureau.

Volunteer Experience

Board Member, SPON (Stop Polluting Our Newport) 2021 – present

- Aviation Committee

Committee Member, Newport Beach Aviation Committee 2020 – present

- Government Relations & FAA ad hoc committees

Board Member, AirFair 2019 – present

Board Member, Newport Citizens for Responsible Growth 2015 – 2018

- Manage social media and community outreach

Committee Member, Bluffs Environmental Impact Committee 2017 – 2018

Event Coordinator, Girls, Inc. 2009 – 2010

Fundraising Committee Member, Cincinnati Children's Hospital 2005 – 2007

Event Manager, Youth Opportunities United Fundraiser 2006

Publicity Chair, Ault Park Advisory Council 2004 – 2006

- Created and managed outdoor movie event and publicity

Event Manager, Cincinnati Ballet Children's Nutcracker Luncheon 2002 – 2003

- Recruited, trained and managed 60 volunteers
- Managed all aspects of the event for 1,200 attendees

Education

Bachelor of Arts in Communications and Sociology, John Carroll University



MEMORANDUM

To: Board of Supervisors

From: Katrina Foley

Date: April 12, 2021

CC: Office of the Clerk of the Board

Frank Kim, Chief Executive Officer

RE: Additional background information on 2nd District's supplemental agenda items for appointments to various boards, commissions and committees:

S43B – Appointment of Alexander Gonzalez of Costa Mesa to the Orange County Veterans Advisory Council is for a two year term ending 1/2/23 and replaces the expired term held by David Han.

S43C – Appointment of Michael Wellborn of Huntington Beach to the Orange County Parks Commission is for a term concurrent with the 2nd District Supervisor's term of office and replaces the expired term held by Michael Posey.

S43D – Appointment of Ada Briceño of Stanton to the Orange County Human Relations Commission is for a two year term that begins on date of appointment, 4/13/21 – 4/12/23, and replaces the expired term held by Michael Reynolds.

S43E – Appointment of Muriel Ullman of Newport Beach to the Housing and Community Development Commission is to complete the existing two year term that ends 6/30/21 and replaces the expired term held by James Fisler.

S43F – Appointment of David Lee of Corona Del Mar to the John Wayne Airport Arts Commission is for a term concurrent with the 2nd District Supervisor's term of office and replaces the expired term held by Stephanie Ann Bachiero.

S43G – Appointment of Lawrence Grihalva to the Emergency Medical Care Committee is to complete the existing two year term that ends 6/30/21 and replaces the expired term held by Jeffrey Barke.

S43H – Appointment of Rev. Rayna Hamre to the Community Action Partnership of Orange County is for a term concurrent with the 2nd District Supervisor's term off office and replaces the expired term held by Nimusha Punnen Jacob.

S43I – Appointment of Susan Dvorak to the Orange County Airport Commission is for a term concurrent with the 2nd District Supervisor's term of office and replaces the vacant position previously held by Lee Lowrey.



ATTORNEYS AT LAW

18101 Von Karman Avenue
Suite 1800
Irvine, CA 92612
T 949.833.7800
F 949.833.7878

Bradford B. Kuhn
D 949.477.7651
bkuhn@nossaman.com

VIA FEDEX

April 5, 2021

Clerk of the Board of Supervisors
Hall of Administration, Fourth Floor
333 W. Santa Ana Blvd.
Santa Ana, CA 92702

**Re: Orange County Board of Supervisors' April 14, 2021, Resolution of Necessity Hearing:
Demand (i) to Continue the Improper Hearing or, (ii) to Appear and Be Heard**

Dear Board Members:

This firm represents Joe Cruz, Virginia Cruz and the Estate of Henry Cruz (collectively, Owners), owners of the property referred to as San Bernardino County Assessor's Parcel Numbers 1057-263-04 and 1057-263-02, and identified by the County as Parcels E01PD-24-009 and E01PD-24-011 (Property).

This responds to the County's notice of intent to adopt a resolution of necessity (RON) authorizing the condemnation of the Property. For the reasons set forth in this letter, the Owners request that the County continue or postpone the improper RON hearing. If the County proceeds with the RON hearing, the Owners request (i) the opportunity to appear and be heard at the RON hearing, and (ii) this letter be made a part of the record.

Background

By way of background, Henry, Joe, and Virginia Cruz are siblings and have owned the Property since approximately 1974 -- over 45 years. Unfortunately, Henry Cruz was hospitalized with a severe case of COVID-19 on December 13, 2020. Henry was incapacitated, struggling to breathe, and suffering from early dementia from December 13, 2020 until his passing the morning of December 23, 2020. Family and Friends were not allowed to visit or have physical contact with him, and communication was impossible because of his loss of hearing, inability to breathe, weakness, and mental confusion.

On December 14, 2020, the County mailed its offers to Henry Cruz at his home address. Because Mr. Cruz was hospitalized, he never received the offers. Despite the Property also being owned by Joe Cruz and Virginia Cruz, neither Joe nor Virginia have ever lived at the address of Henry Cruz, and likewise therefore did not receive the offers until recently.

Despite the situation, less than 10 days after the offers were mailed to Henry Cruz, the County mailed out its Notice of RON hearing on Christmas Eve, December 24, 2020 -- a day after Henry Cruz had

passed away. Mr. Cruz's family had been struggling with his illness during his hospitalization and has been in mourning since his passing. They are not in a mental state to deal with the County's moving extraordinarily rapidly to condemn their Property, with no regard or compassion for Mr. Cruz or his family.

At the Cruz family's request, the County previously agreed to continue the RON hearing so the Cruz family could secure an appraisal and attempt to resolve this matter without the need for eminent domain. The Cruz family secured an appraisal from an MAI appraiser and provided a settlement proposal to the County with supporting data and comparable sales. Despite the Cruz family's efforts, the County declined to negotiate and instead immediately decided to proceed back on the RON-path. We ask the County to postpone the hearing on the RON for the Property, and encourage staff to continue to engage in good faith negotiations with the Cruz family.

Objections

Should the County decide to proceed with the RON hearing, the Owners object to the RON hearing, and to the County's adoption of such a resolution, on the following grounds:

1. The County Did Not Properly Negotiate with the Owners, and Is Instead Rushing This RON Hearing.

A public agency is required to make an offer to the property owner for the full amount of just compensation, and thereafter engage in good faith negotiations. (Gov. Code, §§ 7267.1, 7267.2.) California Code of Regulations, Title 25, section 6182, subdivision (i)(1) states:

Prior to commencement of an eminent domain proceeding the **public entity shall make reasonable efforts to discuss with the owner its offer to purchase the owner's real property.** The owner shall be given a reasonable opportunity to present material which he believes to be relevant as to the question of value and to suggest modification in the proposed terms and conditions of the purchase, and the public entity shall carefully consider the owner's presentation.

Subdivision (i)(1) states that if the evidence suggests a modification in the price, "an appropriate price adjustment shall be made and the new amount determined to be just compensation shall be promptly offered in writing to the owner." As one court explained: "**Government Code section 7267.1 imposes an affirmative obligation on a public entity seeking to condemn property to acquire that property by negotiation.**" (*Johnston v. Sonoma County Agricultural Preservation and Open Space Dist.* (2002) 100 Cal.App.4th 973, 988, emphasis added.)

Recently enacted changes to the Eminent Domain law make even more clear the need for a negotiation period between the time of the condemning agency's offer and the passage of a resolution of necessity. Under the law, the County was required to offer the Owners \$5,000 to obtain an independent appraisal in order to evaluate the County's offer. While the County's "offer" contains language concerning such an opportunity, the language is rendered meaningless by the fact that the County proceeded with this RON hearing without engaging in good faith negotiations with the Cruz family. This clearly violates California law.

2. The County Improperly Downzoned the Property -- and Denied Development Permits -- to Depress its Value.

The Owners believe the County has also engaged in efforts to re-zone the Owners' Property to depress its value. Such zone changes are improper and must be disregarded as a project influence. (See *City of San Diego v. Rancho Penasquitos Partnership* (2003) 105 Cal.App.4th 1013.) The County is grossly abusing its powers, and has violated the law, as it is unlawful for the County to "take any other action coercive in nature, in order to compel an agreement on the price to be paid for the property." (See Gov. Code, § 7267.5.) The County's proposed initiation of condemnation proceedings is not being done in good faith.

For example, in the Owners' discussions with the City of Chino, the Owners learned that the County had annexed the parcels in 2003 and at that time the zoning was changed from agricultural to Open-Space to keep it open and natural due to possible flooding from the Prado Dam. The Owners had offers from developers to purchase the Property, but the developers were denied permits to develop the Property.

At that time, the County had already started pre-acquisition planning activities, including surveys, appraisals, etc., and the Prado Dam Hardship Program to acquire property. After going through bankruptcy, the Orange County Board of Supervisors authorized once again starting up of pre-acquisition planning activities for the Prado Dam, and the County began acquiring numerous properties for the project. The Cruz family was never contacted. In 2001-2002, the County was to initiate pre-acquisition activities for the remaining properties and complete offers for property most impacted by the proposed project (estimated 55 owners). Again, the Cruz family was never contacted. Between 2003 and 2004, all remaining offers were to be made and possession of all property rights required for the proposed project were to be acquired. Again, the Cruz family was never contacted.

It appears that all of a sudden, in 2003, out of the blue, the City of Chino decided to annex the parcels (for no stated purpose) and downgrade the zoning to Open Space. The City's Planning Department informed the Cruz family that this zoning was implemented to keep the Property open and clear for possible flooding from the Prado Dam.

Now, in 2021, after more than 30 years of the County's planning, negotiating and plotting to acquire property for the Prado Dam project, the County finally contacted the Cruz family. Absent the Dam project and anticipated flooding, the Cruz family's Property would have secured a zone change. In fact, the City of Chino approved other developments in the vicinity, even ones that were in the potential flood zone (such as the Edgewater residential project in 2005 -- which occurred after the Preserve Specific Plan was adopted banning development below the 566' flood zone). If the City Council was willing to do so for other properties, why not the Cruz family's Property? Prohibiting any development of the Property, or downzoning the Property, in anticipation of a potential future acquisition, must be disregarded or must be considered a taking itself.

The County's appraisal and offer fails to consider these actions and instead values the Cruz family's property as open space mitigation. This is improper, and the County should re-appraise the Property based on a proper highest and best use.

3. The County's Acquisition Will Render the Remainder Property an Uneconomic Remnant.

As indicated above, Government Code section 7267.2 requires that the County make a legitimate offer of compensation based upon an approved appraisal prior to initiating condemnation proceedings. To the extent a precondemnation offer was even made, the County failed to comply with this requirement as its appraisals and the offers based on those appraisals failed to analyze appropriately the damages that will be caused by the acquisition. In particular, the appraisals/offers dramatically underestimate the obvious detrimental impact on the portions of the Property not sought to be acquired. In particular, the County's proposed condemnation will encumber many portions of the Property, leaving orphaned, irregularly shaped remnants, and leaving the other pieces with likely no use or access, meaning no economically viable use of the remainder property exists. In these circumstances, Government Code section 7267.7 imposes a mandatory requirement that the County offer to purchase the entire Property. ("If the acquisition of only a portion of a property would leave the remaining portion in such a shape or condition as to constitute an uneconomic remnant, the public entity shall offer to acquire the entire property if the owner so desires.") And, since the County's appraiser failed to recognize that the taking will render the remainder valueless, the purported offer fails to meet statutory requirements.

4. The County's Adoption of a Resolution of Necessity Will Violate CEQA.

California law is clear that a public agency must comply with the California Environmental Quality Act (CEQA) before adopting a resolution of necessity to condemn property. (*City of Stockton v. Marina Towers* (2009) 171 Cal.App.4th 93, 108 ["Compliance with CEQA is mandatory before a public entity may condemn property for a proposed project."].) Requiring CEQA-compliance before commencing condemnation proceedings makes perfect sense, as (i) an agency is prohibited from undertaking an action that would taint its consideration of project alternatives, and (ii) the acquisition of private property is considered a definite course of action which is prohibited prior to preparing, finalizing and considering an Environmental Impact Report (EIR). (See Cal. Code Regs., tit. 14, § 15004, subd. (b)(2); *City of San Jose v. Great Oaks Water Co.* (1987) 192 Cal.App.3d 1005, 1017 [compliance with CEQA is a precondition of the institution of eminent domain proceedings]; *Save Tara v. City of West Hollywood* (2008) 45 Cal.4th 116, 140-142). CEQA is the "environmental full disclosure act" to assess the environmental impact of all proposed "projects."

Here, the County has undertaken no environmental analysis for decades. The County has not analyzed changes in property uses, impacts from its project due to the changes in land uses, or issues pertaining to soil erosion or other impacts. Without such adequate consideration, the County will violate CEQA and its eminent domain action will be dismissed. (*Burbank-Glendale-Pasadena Airport v. Hensler* (1991) 233 Cal.App.3d 577, 599 ["[A] successful CEQA challenge to the adoption of a resolution of necessity would also constitute a defense to the eminent domain proceeding."].)

5. The County Is Prohibited From Rubber-Stamping the Resolution of Necessity.

The County must arrive at any decision to take the Property by engaging in a "good faith and judicious consideration of the pros and cons of the issue." (*Redevelopment Agency v. Norm's Slauson*

(1985) 173 Cal.App.3d 1121, 1125.) County Board members cannot simply “rubber-stamp” a predetermined result. (*Id.* at p. 1127.) Yet, rubber-stamping appears to be the County’s plan.

The County has, by virtue of its previous actions, irrevocably committed itself to take the Property, regardless of any evidence that might be presented at this hearing. (See *Norm’s Slauson, supra*, 173 Cal.App.3d at p. 1127.) This is evidenced by issuing an offer and sending out a RON notice less than 10 days later -- and on Christmas Eve. The County’s hearing on the resolution of necessity will therefore be affected by the prior elimination of any discretion whatsoever, which will deprive any approved resolution of its validity. (*Ibid.*)

Conclusion

For the reasons set forth in this letter, the County’s Board members cannot validly adopt the proposed resolution of necessity. The Owners therefore request that the Board members not proceed with the hearing on that resolution or, if they proceed, vote to reject said defective resolution.

Thank you for your consideration of this matter.

Regards,



Bradford B. Kuhn
Nossaman LLP



Revision to ASR and/or Attachments

Date: April 8, 2021
To: Clerk of the Board of Supervisors
CC: County Executive Office
From: Frank Kim, County Executive Officer
Re: ASR Control #: N/A, Meeting Date 4/13/21, Item No. # S45A
Subject: Condemnation Action, Riverside County, Prado Dam Project

Frank Kim
 Digitally signed by Frank Kim
 DN: cn=Frank Kim, o=County of Orange, ou=CEO,
 email=frank.kim@ocgov.com,
 c=US
 Date: 2021.04.08 12:51:51 -0700

RECEIVED
 CLERK OF THE BOARD
APR 08 2021

Explanation: Please correct the Agenda Staff Report to reflect that the legal entity taking action is the Orange County Flood Control District, not the Board of Supervisors.

Revised Recommended Action(s)

Acting as the governing board of the Orange County Flood Control District:

1. Conduct public hearing.

Make modifications to the:

Subject Background Information Summary Financial Impact

LEGAL ENTITY TAKING ACTION: ~~Orange County Flood Control District Board of Supervisors~~

Revised Attachments (attach revised attachment(s) and redlined copy(s))

RECEIVED
CLERK OF THE BOARD

APR 07 2021

S45A



County Executive Office

Memorandum

April 5, 2021

To: Clerk of the Board of Supervisors
From: Frank Kim, County Executive Officer
Subject: Exception to Rule 21

Digitally signed by Frank Kim
DN: cn=Frank Kim, o=County
of Orange, ou=CEO,
email=frank.kim@ocgov.com,
c=US
Date: 2021.04.06 08:44:10
-0700

The County Executive Office is requesting a Supplemental Agenda Staff Report for the April 13, 2021, Board Hearing.

Agency: County Executive Office
Subject: Condemnation Actions, Riverside County, Prado Dam Project
Districts: All Districts

Reason for supplemental: In late August 2020, the United States Army Corps of Engineers (Corps) informed the Orange County Flood Control District (OCFCD) that in order to meet an April 30, 2021, Corps deadline to award the construction contract for the Santa Ana River Mainstem/Prado Dam Project spillway, OCFCD in conjunction with CEO-Real Estate must acquire flowage easements or other property interests in more than 45 properties expeditiously. In order to obtain possession within the timeframe set by the Corps, properties for which offers have been made in accordance with the required notice, need to be considered by the Board as soon as they are ready. This Agenda Staff Report and attachments were finalized after the filing deadline to the Clerk of the Board.

Concur:

A handwritten signature in black ink, appearing to read "A. Do".

Chairman Andrew Do, Supervisor, First District

cc: Board of Supervisors
County Executive Office
County Counsel

APR 07 2021

Agenda Item 545A
Clerk's Use Only



SUPPLEMENTAL AGENDA ITEM AGENDA STAFF REPORT

MEETING DATE: 04/13/21

LEGAL ENTITY TAKING ACTION: Board of Supervisors

BOARD OF SUPERVISORS DISTRICT(S): All Districts

SUBMITTING AGENCY/DEPARTMENT: County Executive Office

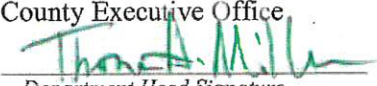
DEPARTMENT HEAD REVIEW: 
Department Head Signature

DEPARTMENT CONTACT PERSON(S): Thomas A. Miller (714) 834-6019
James Treadaway (714) 667-9700

SUBJECT: Condemnation Action, San Bernardino County, Prado Dam Project

CEO CONCUR

Digitally signed by Frank Kim
DN: cn=Frank Kim, o=County of
Orange, ou=CEO,
email=frank.kim@ocgov.com,
c=US
Date: 2021.04.06 08:43:46 -07'00'

CEO Signature

COUNTY COUNSEL REVIEW

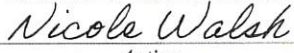
Action

Approve resolution to form
County Counsel Signature

CLERK OF THE BOARD

Public Hearing
2/3 Vote

Budgeted: Yes

Current Year Cost: \$232,500

Annual Cost: N/A

Staffing Impact: No

of Positions:

Sole Source: N/A

Current Fiscal Year Revenue: N/A

Funding Source: Fund 404: 100%

County Audit in last 3 years N/A

Prior Board Action: 10/06/2020 #4, 01/28/2003 #40, 12/07/1999 #49

RECOMMENDED ACTION(S)

1. Conduct public hearing.
2. At the conclusion of the hearing, make the following findings:
 - a) Final Environmental Impact Report No. 583 was previously certified by the Board of Supervisors on November 28, 1989, and reflects the independent judgment of the Orange County Flood Control District as Lead Agency. Final Supplemental Environmental Impact Statement/Environmental Impact Report No. 583 was previously certified by the Orange County Planning Commission on December 19, 2001, and reflects the independent judgment of the Orange County Planning Commission as Lead Agency. Final Environmental Impact Report No. 583 and Final Supplemental Environmental Impact Statement/Environmental

Impact Report No. 583 adequately addressed and fully analyzed project environmental impacts for the Santa Ana River Mainstem Project, as well as the Prado Dam Project, which is a necessary and contemplated element of the Santa Ana River Mainstem Project. Both the Final Environmental Impact Report No. 583 and Final Supplemental Environmental Impact Statement/Environmental Impact Report are complete and adequately satisfy the requirements of CEQA for the Santa Ana River Mainstem Project, which includes the Prado Dam Project.

- b) The circumstances of the Project are substantially the same as when Final Environmental Impact Report No. 583 and Final Supplemental Environmental Impact Statement/Environmental Impact Report No. 583 were certified, and Final Environmental Impact Report No. 583 and Final Supplemental Environmental Impact Statement/Environmental Impact Report No. 583 adequately addressed the effects of the proposed Project. No substantial changes have been made in the Project, no substantial changes have occurred in the circumstances under which the Project is being undertaken and no new information of substantial importance to the Project that was not known or could not have been known when the Final Environmental Impact Report No. 583 and Final Supplemental Environmental Impact Statement/Environmental Impact Report No. 583 were certified has become known in relation to these proposed condemnation actions. Thus, no further CEQA review is required.
 - c) Final Environmental Impact Report No. 583 and Final Supplemental Environmental Impact Statement/Environmental Impact Report No. 583 are adequate to satisfy the requirements of CEQA for the proposed condemnation actions.
 - d) All mitigation measures are fully enforceable pursuant to CEQA, Public Resources Code Section 21081.6(b), and have either been adopted as conditions, incorporated as part of the Project design or included in the procedures of Project implementation.
3. At the conclusion of the hearing, adopt the Resolutions of Necessity attached as Attachment E and F to this Agenda Staff Report, which include the above-described CEQA findings and also the findings required by the California Eminent Domain Law for adoption of a Resolution of Necessity, and which direct and authorize County Counsel and/or outside eminent domain counsel, the firm of Burke, Williams & Sorensen, LLP, pursuant to its existing contract with the Orange County Flood Control District, to file a complaint to condemn the interest in real property as described in the attached Resolutions of Necessity.
4. At the conclusion of the hearing, direct and authorize the Auditor-Controller, upon request by County Counsel, to encumber and transfer funds to the State Treasurer's Condemnation Deposits Fund, in amounts to be specified by County Counsel, in a total amount as described in the Resolutions of Necessity; and to be made as one or more deposits of estimated compensation in the condemnation proceedings; and to encumber such additional funds, and to transfer funds as may be requested by County Counsel, and if necessary to satisfy any court orders for higher deposits or payment of greater compensation, or as necessary to pay for title insurance and other fees and costs in connection with the acquisition of the Subject Property Interests pursuant to each Resolution of Necessity.

SUMMARY:

Conducting a public hearing and considering the adoption of the Resolutions of Necessity that will allow the Orange County Flood Control District to acquire property for the Santa Ana River Mainstem/Prado Dam Project, including uneconomic remnants, will provide protection to the public from flood and storm waters from the potential effects of a 190-year flood/storm event.

BACKGROUND INFORMATION:

On December 7, 1999, the Board of Supervisors (Board) for the Orange County Flood Control District (District) authorized the initiation of the Prado Dam Project Real Property Acquisition Program. On January 28, 2003, your Board authorized the execution of a Project Cooperation Agreement and Second Modification to the Local Cooperation Agreement for the Santa Ana River Mainstem Project, and on October 6, 2020, your Board authorized Amendment Number 1 to the Project Cooperation Agreement with the Recommended Actions including authorizing the Director of OC Public Works or designee to execute ancillary documents or Relocation Agreements approved by County Counsel not to exceed \$1 million per utility or property owner relocation need per fiscal year. The Project Cooperation Agreement requires the local sponsors of the Santa Ana River Mainstem Project, including the District, to acquire real property interests and perform relocation/protection of utilities, streets and highways as necessary for construction and related revised flood control operations.

The recommended action, adoption of the proposed Resolutions of Necessity (Resolutions), would find and declare it to be necessary to institute eminent domain proceedings to acquire the real property interest described below, which is located in the County of San Bernardino, for the District's Santa Ana River Mainstem/Prado Dam Project (Project), which will raise the Prado Dam flood basin and expand the potential inundation area up to 566 feet above sea level, and find and declare that the public interest and necessity require the Project for the purpose of controlling flood and storm waters in order to protect the safety, health and welfare of residents and properties within the County of Orange from the potentially devastating effects of a 190-year flood/storm event. In particular, the recommended action would find and declare that it is necessary for the District to acquire flowage easements in the Subject Property as described more fully in the Resolutions of Necessity (Subject Property Interest), in order to meet the deadline of the United States Army Corps of Engineers (Corps) to award the contract for construction of the Project's spillway in 2021. If the Corps' schedule is not met, vital Project funding may be lost or delayed, thus exposing the citizens of Orange County to a prolonged risk of property damage and personal injury from a major storm event. The Subject Property Interest below the 566-foot flood line is necessary for the Project, in order to provide sufficient protection from storm events and flooding to those downstream from the Prado Dam and because the area of the Subject Property Interest will be exposed to greater risk or frequency of inundation as a result of the Prado Dam's increased reservoir capacity once the spillway is increased in height. Staff has reviewed the conclusions reached by the District's appraiser, and has determined the acquisition of the Flowage Easement will not leave the remainder in such size, shape or condition as to be of little market value. Therefore, there is no need for the District to make an offer to acquire or acquire the entire parcel."

A more detailed description of the intended public use of, and necessity for, this acquisition is contained in the accompanying OC Public Works Memoranda, attached hereto as Attachment B, which is incorporated herein by this reference and that provides substantial information supporting the requested findings contained in the proposed Resolutions. The information presented in this Agenda Staff Report and in that Memoranda are legally sufficient to show that the public interest and necessity require the Project for the purposes specified by the Orange County Flood Control Act (California uncodified Water Code, Act 5682, section 2, also referred to as Water Code App. sections 36-1 et seq.) (Act), including, but not limited to, the control of flood and storm waters. The District is authorized to acquire the Subject Property Interest and to exercise the power of eminent domain for the public uses described herein and in the accompanying OC Public Works Memoranda under the California Constitution and the California Eminent Domain Law (Code of Civil Procedure Sections 1230.010 et seq., and 1240.010 et seq., including without limitation Sections 1240.110, 1240.410, and 1240.420), Government Code Section 25350.5 and the Act.

Accordingly, County Counsel and OC Public Works/Infrastructure Programs/Flood Programs request your Board, acting in its capacity as the governing Board of the District, to adopt the proposed Resolutions to authorize and direct County Counsel and/or outside eminent domain counsel, the law firm of Burke Williams Sorenson LLP, pursuant to its existing contract with the District, to file to file and pursue proceedings to condemn and acquire the Subject Property Interests, which are more particularly described in the proposed Resolutions of Necessity attached as Attachment E and F.

Although the Subject Property Interest is located in the County of San Bernardino, it is within the reach of the District's extraterritorial power of eminent domain pursuant to Sections 2 and 16 of the Act.

To the extent the Subject Property Interest is already devoted to a public use, the use of the Subject Property Interest for the District's Project is a compatible use that will not unreasonably interfere with or impair the continuance of the public use as it presently exists or may reasonably be expected to exist in the future (California Code of Civil Procedure Section 1240.510), or the use of the Subject Property Interest for the District's Project is a more necessary public use than is the presently existing public use (California Code of Civil Procedure Section 1240.610).

To the extent the acquisition of the portion of the Subject Property that is necessary for the Project will leave the remainder in such size, shape or condition as to be of little market value, any remnants being acquired are acquired in accordance with Article 5 of the Eminent Domain Law (commencing with Section 1240.410 of the Code of Civil Procedure).

Compliance with CEQA: The acquisition of property is a necessarily included element of the project considered in Final Environmental Impact Report (EIR) No. 583, certified by the Board on November 28, 1989, and Final Supplemental Environmental Impact Statement (EIS) /EIR No. 583, certified by the Orange County Planning Commission on December 19, 2001, which adequately addressed the effects of the proposed project. No substantial changes have been made in the Project, no substantial changes have occurred in the circumstances under which the project is being undertaken and no new information of substantial importance to the project that was not

known or could not have been known when the Final EIR No. 583 and Final Supplemental EIS/EIR No. 583 were certified has become known; therefore, no further environmental review is required.

FINANCIAL IMPACT:

Appropriations of \$232,500 are included in Flood Fund 404 FY 2020-21 Budget for issuance of a one-time cost of \$232,500 in the amounts and from the Fund Nos listed below:

	<u>Property Owner Name</u>	<u>Amount</u>	<u>JCN</u>	<u>Account Coding</u>
1	Cruz Henry & Joe	\$182,000	ESP2134	404-080-404-LS43-4100-ESP2134
2	Cruz Henry & Virginia	\$50,500	ESP2134	404-080-404-LS43-4100-ESP2134
Total		\$ 232,500.00		

Payment of these costs shall be made upon Board approval of the proposed recommended actions. However, if payments are not made in FY 2020-2021, they will be included in the recommended budget for FY 2021-2022. Additional presently unknown costs may also include payments for title fees and other costs upon recordation and relocation benefits to occupants, as well as the potential for other required payments that a court may order be deposited and/or paid in the condemnation actions. Any unknown costs will be absorbed within the existing appropriation of Flood Fund 404.

STAFFING IMPACT:

N/A

REVIEWING AGENCIES:

OC Public Works

ATTACHMENT(S):

Attachment A - Code Provisions

Attachment B - OC Public Works Memorandum

Attachment C - Real Estate Acquisition Questionnaire

Attachment D - Final Supplemental Environmental Impact Statement and Report No. 583

Attachment E - Resolution of Necessity (E01PD-24-009 Cruz)

Attachment F - Resolution of Necessity (E01PD-24-011 Cruz)

Attachment G - Notice of Intent to Adopt Resolution of Necessity (E01PD-24-009 Cruz)

Attachment H - Notice of Intent to Adopt Resolution of Necessity (E01PD-24-011 Cruz)

ATTACHMENT A

O.C. Flood Control Act provisions

WATER -- UNCODIFIED ACTS
Orange County Flood Control Act (1927 ch 723)

§ 2. Purposes of Act; Powers of district

(a) The purposes of this act are to provide for the control of the flood and storm waters of the district, and the flood and storm waters of streams that have their source outside of the district, but which flow into the district, and to conserve those waters for beneficial and useful purposes by spreading, storing, retaining, and causing them to percolate into the soil within the district, or outside the district, or to save or conserve in any manner all or any of those waters and protect from damage from those flood or storm waters, the harbors, waterways, public highways, and property in the district.

(b) The **Orange County Flood Control District** is hereby declared to be a body corporate and politic and has all of the following powers:

- (1)** To have perpetual succession.
- (2)** To sue and be sued in the name of the district in all actions and proceedings in all courts and tribunals of competent jurisdiction.
- (3)** To adopt a seal and alter it at pleasure.
- (4)** To take by grant, purchase, gift, devise, or lease, and to hold, use, enjoy, and to sell, lease, exchange, or dispose of real or personal property of every kind, within or outside the district, necessary to the full exercise of its powers.
- (5)** To acquire, or contract to acquire, lands, rights-of-way, easements, privileges and property of every kind, and to construct, maintain, and operate any and all works or improvements within or outside the district necessary or proper to carry out any of the objects or purposes of this act, and to complete, extend, add to, repair, or otherwise improve any works or improvements acquired by it as authorized in this act.
- (6)** To exercise the right of **eminent domain**, either within or outside the district, to take any property necessary to carry out any of the objects or purposes of this act.
- (7)** To incur indebtedness, and to issue bonds in the manner provided in this act.
- (8)** To cause taxes or assessments to be levied and collected for the purpose of paying any obligation of the district in the manner provided in this act.
- (9)** To make contracts, and to employ labor, and to do all acts necessary for the full exercise of the powers of the district, or any of the officers thereof, by this act.
- (10)** To grant or otherwise convey to counties, cities and counties, cities, or towns,

ATTACHMENT A

easements for street and highway purposes, over, along, in, through, across, or under any real property owned by the district.

(11) To remove, carry away, and dispose of any rubbish, trash, debris, or other inconvenient matter that may be dislodged, transported, conveyed, or carried by means of, through, in, or along the works and structures operated or maintained hereunder and deposited upon the property of the district or elsewhere.

(12) To sell or dispose of any property, or any interest therein, or lease or rent any property, or any interest therein, whenever, in the judgment of the board of supervisors, the property, or any interest therein or part thereof, is not required for the purposes of the district, or property may be leased, or included in community leases embracing adjoining lands, for any purpose, including leases for mining or extracting oil, gas, hydrocarbon substances, or other minerals, without interfering with the use of the property for the purposes of the district. If it appears that wells drilled upon private lands are draining or may drain oil, gas, or other hydrocarbon substances from lands owned by the district and operations for the production of oil, gas, or other hydrocarbons on land owned by the district might interfere with the use of that land for the purposes of the district, the district may enter into agreements with the owners or operators of the wells for the payment of compensation to the district for drainage in lieu of drilling offset wells upon the land owned by the district, and to pay any compensation received into the general fund of the district and use the compensation for the purposes of this act. However, nothing in this section authorizes the board of supervisors, or other governing body of the district, or any officer thereof, to sell, lease, or otherwise dispose of any water, water right, reservoir space, or storage capacity, or any interest or space therein, except as provided by Section 17. The district may also grant to the United States of America, or any agency thereof authorized to accept and pay for land which lies within any channel, dam, or reservoir site, improved or constructed, in whole or in part, with federal funds, upon the payment to the district of the actual cost thereof as determined by the board of supervisors of the district. The district, by and through its board of supervisors, may warrant and guarantee the title of all lands so transferred to the United States under this section.

(13) Pursuant to paragraph (12), to lease or rent any property, or any interest therein or part thereof, if the board adopts a resolution that meets all of the following requirements, as applicable:

(A) Includes all of the following findings, based on evidence set forth in the minutes of the meeting:

(i) The property, or any interest therein or part thereof, is no longer or not yet needed for district uses and purposes, including, but not limited to, flood protection and water conservation, and the lease or rental use will not conflict with the uses and purposes of the district.

(ii) The lease or rental is consistent with the city or county general plan, specific plan, or other plans or policies adopted for the area within which the property is located, including any plans and regulations adopted pursuant to Chapter 4 (commencing with [Section 8400](#)) of [Part 2 of Division 5 of the Water Code](#).

(iii) The lease or rental is consistent with city or county zoning ordinances, regulations, and policies adopted for the area within which the property is located.

ATTACHMENT A

(iv) The lease or rental is consistent with the city or county building regulations and policies adopted for the area within which the property is located.

(B) In the case of a rental, specifies the rental period and the approximate date on which the property will be needed for the uses and purposes of the district.

(C) For any property acquired by the district through **eminent domain**, declares that the property was acquired through **eminent domain** in accordance with Title 7 (commencing with [Section 1230.010](#)) of Part 3 of the Code of Civil Procedure.

(14) To monitor, test, or inspect drainage, flood, storm, or other waters within the district for the purpose of recording, determining, and reporting the quality of the waters to appropriate regional water quality control boards.

(15) To assist the County of Orange and any city within the county in emergency operations to control or mitigate the effect of tides, waves, and ocean currents on the Orange County shoreline.

(16) To carry on technical and other investigations, examinations, or tests of all kinds, make measurements, collect data, and make analyses, studies, and inspections pertaining to water supply, control of floods, use of water, water quality, nuisance, pollution, waste, and contamination of water, both within and outside the district.

(17) To regulate, prohibit, or control the discharge of pollutants, waste, or any other material into the district's facilities by requiring dischargers to obtain a permit from the district prior to any discharge and by prohibiting the discharge of pollutants or other material which does or may cause a nuisance into the district's facilities without first obtaining a permit from the district, but, if a federal permit has been issued for the discharge, a permit may be issued by the district at no fee to the discharger; except as provided in this act, to require a fee to be collected prior to the issuance of a discharge permit, if the amount of the fee does not exceed the cost of issuing the permit; to require all permitholders to indemnify the district from any and all damages, penalties, or other expenses imposed on or required of the district by state or federal agencies due to any discharge by the permitholders into the district facilities.

(18) To establish compliance with any federal, state, or local law, order, regulation, or rule relating to water pollution or the discharge of pollutants, waste, or any other material into the district's facilities. For this purpose, any authorized representative of the district, upon presentation of his or her credentials or, if necessary under the circumstances, after obtaining an inspection warrant pursuant to Title 13 (commencing with [Section 1822.50](#)) of Part 3 of the Code of Civil Procedure, has the right of entry to any premises on which a water pollution, waste, or contamination source is located for the purpose of inspecting the source, including securing samples of discharges therefrom, or any records required to be maintained in connection therewith by federal, state, or local law, order, regulation, or rule.

Code of Civil Procedure provisions

Code of Civil Procedure § 1230.010. Short title

This title shall be known and may be cited as the Eminent Domain Law.

Code of Civil Procedure § 1240.010. Exercise of power for public use

The power of eminent domain may be exercised to acquire property only for a public use. Where the Legislature provides by statute that a use, purpose, object, or function is one for which the power of eminent domain may be exercised, such action is deemed to be a declaration by the Legislature that such use, purpose, object, or function is a public use.

Code of Civil Procedure § 1240.110. Acquisition of certain interests in property; enumeration; restriction

(a) Except to the extent limited by statute, any person authorized to acquire property for a particular use by eminent domain may exercise the power of eminent domain to acquire any interest in property necessary for that use including, but not limited to, submerged lands, rights of any nature in water, subsurface rights, airspace rights, flowage or flooding easements, aircraft noise or operation easements, right of temporary occupancy, public utility facilities and franchises, and franchises to collect tolls on a bridge or highway.

(b) Where a statute authorizes the acquisition by eminent domain only of specified interests in or types of property, this section does not expand the scope of the authority so granted.

Code of Civil Procedure § 1240.510. Authority; reference in complaint and resolution

Any person authorized to acquire property for a particular use by eminent domain may exercise the power of eminent domain to acquire for that use property appropriated to public use if the proposed use will not unreasonably interfere with or impair the continuance of the public use as it then exists or may reasonably be expected to exist in the future. Where property is sought to be acquired pursuant to this section, the complaint, and the resolution of necessity if one is required, shall refer specifically to this section.

ATTACHMENT A

Code of Civil Procedure § 1240.610. Authority; reference in complaint and resolution

Any person authorized to acquire property for a particular use by eminent domain may exercise the power of eminent domain to acquire for that use property appropriated to public use if the use for which the property is sought to be taken is a more necessary public use than the use to which the property is appropriated. Where property is sought to be acquired pursuant to this section, the complaint, and the resolution of necessity if one is required, shall refer specifically to this section.

Code of Civil Procedure § 1245.235. Notice and hearing; contents; conduct

(a) The governing body of the public entity may adopt a resolution of necessity only after the governing body has given each person whose property is to be acquired by eminent domain and whose name and address appears on the last equalized county assessment roll notice and a reasonable opportunity to appear and be heard on the matters referred to in [Section 1240.030](#).

(b) The notice required by subdivision (a) shall be sent by first-class mail to each person described in subdivision (a) and shall state all of the following:

- (1) The intent of the governing body to adopt the resolution.
- (2) The right of such person to appear and be heard on the matters referred to in [Section 1240.030](#).
- (3) Failure to file a written request to appear and be heard within 15 days after the notice was mailed will result in waiver of the right to appear and be heard.

(c) The governing body, or a committee of not less than 11 members thereof designated by the governing body if the governing body has more than 40 members, shall hold a hearing at which all persons described in subdivision (a) who filed a written request within the time specified in the notice may appear and be heard on the matters referred to in [Section 1240.030](#). Such a committee shall be reasonably representative of the various geographical areas within the public entity's jurisdiction. The governing body need not give an opportunity to appear and be heard to any person who fails to so file a written request within the time specified in the notice. If a committee is designated by the governing body pursuant to this subdivision to hold the hearing, the committee, subsequent to the hearing, shall provide the governing body and any person described in subdivision (a) who has appeared before the committee with a written summary of the hearing and a written recommendation

ATTACHMENT A

as to whether to adopt the resolution of necessity. Any person described in subdivision (a) who has appeared before the committee shall also be given an opportunity to appear and be heard before the governing body on the matters referred to in [Section 1240.030](#).

(d) Notwithstanding subdivision (b), the governing body may satisfy the requirements of this section through any other procedure that has given each person described in subdivision (a) reasonable written personal notice and a reasonable opportunity to appear and be heard on the matters referred to in [Section 1240.030](#).

Code of Civil Procedure § 1245.240. Vote required for adoption

Unless a greater vote is required by statute, charter, or ordinance, the resolution shall be adopted by a vote of two-thirds of all the members of the governing body of the public entity.

Government Code provisions

Government Code § 25350.5. Power of eminent domain

The board of supervisors of any county may acquire by eminent domain any property necessary to carry out any of the powers or functions of the county.

Government Code § 7267.1. Acquisition by negotiation; appraisal

(a) The public entity shall make every reasonable effort to acquire expeditiously real property by negotiation.

(b) Real property shall be appraised before the initiation of negotiations, and the owner, or the owner's designated representative, shall be given an opportunity to accompany the appraiser during his or her inspection of the property. However, the public entity may prescribe a procedure to waive the appraisal in cases involving the acquisition by sale or donation of property with a low fair market value.

Government Code § 7267.2. Just compensation; property offered for sale by owner

(a)(1) Prior to adopting a resolution of necessity pursuant to [Section 1245.230 of the Code of Civil Procedure](#) and initiating negotiations for the acquisition of real property, the public entity shall establish an amount that it believes to be just compensation therefor, and shall make an offer to the owner or owners of record to acquire the property for the full amount so established, unless the owner cannot be located with reasonable diligence. The offer may be conditioned upon the legislative body's ratification of the offer by execution of a contract of acquisition or adoption of a resolution of necessity or both. The amount shall not be less than the public entity's approved appraisal of the fair market value of the property. A decrease or increase in the fair market value of real property to be acquired prior to the date of valuation caused by the public improvement for which the property is acquired, or by the likelihood that the property would be acquired for the improvement, other than that due to physical deterioration within the reasonable control of the owner or occupant, shall be disregarded in determining the compensation for the property.

ATTACHMENT A

(2) At the time of making the offer described in paragraph (1), the public entity shall provide the property owner with an informational pamphlet detailing the process of eminent domain and the property owner's rights under the Eminent Domain Law.

(b) The public entity shall provide the owner of real property to be acquired with a written statement of, and summary of the basis for, the amount it established as just compensation. The written statement and summary shall contain detail sufficient to indicate clearly the basis for the offer, including, but not limited to, all of the following information:

(1) The date of valuation, highest and best use, and applicable zoning of property.

(2) The principal transactions, reproduction or replacement cost analysis, or capitalization analysis, supporting the determination of value.

(3) If appropriate, the just compensation for the real property acquired and for damages to remaining real property shall be separately stated and shall include the calculations and narrative explanation supporting the compensation, including any offsetting benefits.

(c) Where the property involved is owner-occupied residential property and contains no more than four residential units, the homeowner shall, upon request, be allowed to review a copy of the appraisal upon which the offer is based. The public entity may, but is not required to, satisfy the written statement, summary, and review requirements of this section by providing the owner a copy of the appraisal on which the offer is based.

(d) Notwithstanding subdivision (a), a public entity may make an offer to the owner or owners of record to acquire real property for less than an amount that it believes to be just compensation therefor if (1) the real property is offered for sale by the owner at a specified price less than the amount the public entity believes to be just compensation therefor, (2) the public entity offers a price that is equal to the specified price for which the property is being offered by the landowner, and (3) no federal funds are involved in the acquisition, construction, or project development.

(e) As used in subdivision (d), "offered for sale" means any of the following:

(1) Directly offered by the landowner to the public entity for a specified price in advance of negotiations by the public entity.

(2) Offered for sale to the general public at an advertised or published specified price, set no more than six months prior to, and still available at, the time the public entity initiates contact with the landowner regarding the public entity's possible acquisition of the property.

ATTACHMENT A

Government Code § 65402. Acquisition or disposition of property; construction of buildings; requirements before action

(a) If a general plan or part thereof has been adopted, no real property shall be acquired by dedication or otherwise for street, square, park or other public purposes, and no real property shall be disposed of, no street shall be vacated or abandoned, and no public building or structure shall be constructed or authorized, if the adopted general plan or part thereof applies thereto, until the location, purpose and extent of such acquisition or disposition, such street vacation or abandonment, or such public building or structure have been submitted to and reported upon by the planning agency as to conformity with said adopted general plan or part thereof. The planning agency shall render its report as to conformity with said adopted general plan or part thereof within forty (40) days after the matter was submitted to it, or such longer period of time as may be designated by the legislative body.

If the legislative body so provides, by ordinance or resolution, the provisions of this subdivision shall not apply to: (1) the disposition of the remainder of a larger parcel which was acquired and used in part for street purposes; (2) acquisitions, dispositions, or abandonments for street widening; or (3) alignment projects, provided such dispositions for street purposes, acquisitions, dispositions, or abandonments for street widening, or alignment projects are of a minor nature.

(b) A county shall not acquire real property for any of the purposes specified in paragraph (a), nor dispose of any real property, nor construct or authorize a public building or structure, in another county or within the corporate limits of a city, if such city or other county has adopted a general plan or part thereof and such general plan or part thereof is applicable thereto, and a city shall not acquire real property for any of the purposes specified in paragraph (a), nor dispose of any real property, nor construct or authorize a public building or structure, in another city or in unincorporated territory, if such other city or the county in which such unincorporated territory is situated has adopted a general plan or part thereof and such general plan or part thereof is applicable thereto, until the location, purpose and extent of such acquisition, disposition, or such public building or structure have been submitted to and reported upon by the planning agency having jurisdiction, as to conformity with said adopted general plan or part thereof. Failure of the planning agency to report within forty (40) days after the matter has been submitted to it shall be conclusively deemed a finding that the proposed acquisition, disposition, or public building or structure is in conformity with said adopted general plan or part thereof. The provisions of this paragraph (b) shall not apply to acquisition or abandonment for

ATTACHMENT A

street widening or alignment projects of a minor nature if the legislative body having the real property within its boundaries so provides by ordinance or resolution.

(c) A local agency shall not acquire real property for any of the purposes specified in paragraph (a) nor dispose of any real property, nor construct or authorize a public building or structure, in any county or city, if such county or city has adopted a general plan or part thereof and such general plan or part thereof is applicable thereto, until the location, purpose and extent of such acquisition, disposition, or such public building or structure have been submitted to and reported upon by the planning agency having jurisdiction, as to conformity with said adopted general plan or part thereof. Failure of the planning agency to report within forty (40) days after the matter has been submitted to it shall be conclusively deemed a finding that the proposed acquisition, disposition, or public building or structure is in conformity with said adopted general plan or part thereof. If the planning agency disapproves the location, purpose or extent of such acquisition, disposition, or the public building or structure, the disapproval may be overruled by the local agency.

Local agency as used in this paragraph (c) means an agency of the state for the local performance of governmental or proprietary functions within limited boundaries. Local agency does not include the state, or county, or a city.



ORANGE COUNTY
OC Public Works
MEMORANDUM

County Administration South
601 North Ross Street
Santa Ana, CA 92701
P.O. Box 4048
Santa Ana, CA 92702
(714) 667-8800
info@ocpw.ocgov.com
OCPublicWorks.com

Date: February 24, 2021
To: Members, Board of Supervisors, as Governing Board of the Orange County Flood Control District
From: James Treadaway, Director
Subject: Public Hearing on the Proposed Adoption of a Resolution of Necessity for Condemnation of Real Property Interests for the Prado Dam Project; All Districts (Board of Supervisors' Meeting Date: March 9, 2021) Parcel Nos. E01PD 24- 009, 24-011

Synopsis:

On March 9, 2021, County Executive Office, on behalf of the Orange County Flood Control District ("District"), will present an agenda item requesting that the Orange County Board of Supervisors ("Board"), acting in its capacity as the governing Board of the District, consider for adoption a proposed Resolution of Necessity ("Resolution"), after the duly noticed public hearing and full consideration, authorizing the filing of a condemnation action to acquire real property interests described with particularity below (the "Subject Property Interests") for the Prado Dam Project ("Project"). The Project is necessary to protect the safety, health, and welfare of residents and properties in Orange County from the devastating effects of major storms, including a 190-year storm event. Acquisition of the Subject Property Interests is required for the Project to carry out the Project's flood control purposes.

A. Specific Real Property Interests to be Considered and Acquired:

County Counsel, the OC Public Works Department, and the County Executive Office request your Board to consider for adoption the proposed Resolution (provided as an attachment to the ASR) to authorize and direct County Counsel and/or special litigation counsel, Burke, Williams & Sorensen, LLP (previously approved by your Board for purposes of representing the District on the Project), to file and pursue proceedings to condemn and acquire the Subject Property Interests, which pertain to and affect real property that is owned as a matter of record title by Henry Cruz and Joe Cruz, as tenants in common for Parcel 24-009 and Henry Cruz, a single man and Virginia Cruz, a single woman, as tenants in common for Parcel 24-011 ("Owner"), which real property is located at Pomona Rincon Road & 71 in the City of Chino in San Bernardino County and which Subject Property Interests are described as follows:

Permanent flowage easement in real property that is legally described and depicted by Exhibits A and B attached to the proposed Resolution, which easement area of approximately 266,243 square feet is referred to by the District as Project Parcel No. E01PD-24-009 & 24-011, and which covers San Bernardino County Assessor's Parcel No. 1057-263-02, 1057-263-04 (the "Subject Property Interests").

B. Mailing of Notice of Hearing and Intention to Owners of Record of the Subject Property Interests:

As shown by the Declaration of Mailing that will be on file with the Clerk of the Board prior to the public hearing on this matter, in compliance with Code of Civil Procedure section 1245.235, the Clerk of the Board mailed to Owner a Notice of Intention notifying them of the hearing and of the

- Administrative Services
OC Development Services
OC Facilities Design & Construction Management
OC Facilities Maintenance & CUF
OC Fleet Services
OC Construction
OC Environmental Resources
OC Operations & Maintenance
OC Infrastructure Programs
OC Survey

Public Hearing on the Proposed Adoption of a Resolution of Necessity for Condemnation of Real Property Interests for the Prado Dam Project; All Districts (Board of Supervisors' Meeting Date: March 9, 2021) Parcel Nos. E01PD 24-009, 24-011
February 24, 2021
Page 2 of 4

Board's intention to consider the adoption of the Resolution, and of Owner's right to appear and be heard on the issues described therein.

C. Required Findings and Analysis of Facts Supporting Such Findings:

As a prerequisite to the Board's adoption of the Resolution, at the close of the public hearing, the California eminent domain law (Code of Civil Procedure sections 1245.220 and 1245.230, et seq.) requires the Board to make the findings described below. Staff of the OC Public Works Department has analyzed the Project and its objectives, as well as the acquisitions proposed, with those required findings and legal requirements in mind. Staff hereby recommends to the Board that it make each and all the findings, and staff provides the following analysis and support for these findings:

1. The Public interest and necessity require the Project.

The existing Prado Dam ("Dam") was built in 1941 for flood protection purposes, and is located near the confluence of State Routes 71 and 91. The Dam is operated by the U.S. Army Corps of Engineers ("Corps"). Because of increased urbanization both upstream and downstream of the Dam, accumulation of sedimentation, and environmental factors, the flood control protection of the Dam has significantly diminished over the past 75 years. The Corps considers this situation along the Santa Ana River to constitute "the worst flood threat west of the Mississippi River," with probable devastating impacts to residents and property, resulting in a risk of significant loss of life and personal and economic injury, should a significant flood event occur.

Given these conditions, the Corps developed the Santa Ana River Mainstem ("SAR") Project, as generally described in the Corps' 1988 Phase II General Design Memorandum ("GDM") and Final Supplemental Environmental Impact Statement, which includes construction of Reach 9 (the area of the Project located between Weir Canyon Road in the County of Orange and the Riverside County-Orange County boundary), the raising of the Dam's spillway and embankment and constructing new higher capacity outlet works. Additionally, the Corps developed the Limited Reevaluation Report ("LRR") in 2001 for the purpose of introducing SAR Project modifications following the 1988 GDM, which specifically included three components, the Norco Bluffs (Component A), Prado Basin (Component B), and Reach 9 (Component C). The LRR also served as a basis for the development of the Project Cooperation Agreement ("PCA") between the Corps and the District.

2. The Project is planned or located in the manner that will be most compatible with the greatest public good and least private injury.

Given the location of the Santa Ana River, and given the fact that the Dam embankment, spillway, and reservoir already exist, there is no cost-effective alternative to the Project in order to provide the desired level of flood protection and to achieve the public benefits and protection described above. Prior to 1989, the Corps conducted significant analysis over several years to determine Project requirements and potential impacts to address the serious flood threat discussed above, while mitigating environmental and other impacts and minimizing private injury, as feasible. Based on these studies, the District has determined that it is necessary to acquire the Subject Property Interests. There is no feasible or cost-effective alternative to the Project that would reduce impacts on those private properties affected by the Project.

3. The Subject Property Interests are necessary for the Project.

If the Subject Property Interests are not acquired, the Project could not proceed as planned, which in turn would result in inadequate flood protection downstream of the Prado Dam, potential flooding of, or damage to State Route 91, and a significant risk of property damage, injury, and loss of life suffered by those downstream in Orange County. Per the Corps' Optimal Schedule, the Corps plans to award the contract for construction of the Project's spillway in 2021. It is necessary to acquire the Subject Property Interests so that the Corps can proceed with construction of the Project. If that schedule is not met, vital Project funding may be lost or delayed, thus exposing the citizens of Orange County to a prolonged risk of property

Public Hearing on the Proposed Adoption of a Resolution of Necessity for Condemnation of Real Property Interests for the Prado Dam Project; All Districts (Board of Supervisors' Meeting Date: March 9, 2021) Parcel Nos. E01PD 24-009, 24-011
 February 24, 2021
 Page 3 of 4

damage and personal injury from a major storm event. It is necessary to obtain the Subject Property Interests to prevent and mitigate such risks. In addition, the Subject Property Interests themselves will be exposed to greater risk or frequency of inundation because of the Prado Dam's increased reservoir capacity once the spillway is increased in height. The Project will raise the Prado Dam flood basin and expand the potential inundation area up to 566 feet above sea level.

4. The offer required by California Government Code section 7267.2 was made to the owner of record of the Subject Property Interests.

In conformance with Sections 7267.1 and 7267.2 of the California Government Code and Board of Supervisors Resolution 67-612, an appraisal has been prepared covering the Subject Property Interests. An offer based on said appraisal has been made to Owner, and a written statement showing the appraised value of the Subject Property Interests and summarizing the basis of the value has been delivered to Owner.

Negotiations with the owner initially commenced on December 14, 2020. Negotiations will continue, however, in order to proceed with timely acquisition of this Parcel in accordance with the Project, it is necessary to request the Board of Supervisors to consider the adoption of a Resolution of Necessity to allow us to commence the condemnation process at this time.

5. Compliance with CEQA.

Final Environmental Impact Report No. 583 ("Final EIR No. 583") was previously certified on November 28, 1989 and reflects the independent judgment of the District as Lead Agency. Final Supplemental Environmental Impact Statement/Report No. 583 ("Final Supplemental EIS/EIR No. 583") was previously certified on December 19, 2001, and reflects the independent judgment of the Orange County Planning Commission as Lead Agency. Final EIR No. 583 and Final Supplemental EIS/EIR No. 583, which were prepared and satisfy the requirements of CEQA for the Santa Ana River Mainstem Project, as well as the Prado Dam Project, respectively, adequately addressed and fully analyzed the condemnation action proposed herein, which is a necessarily included element contemplated as part of the whole Project.

- a. The circumstances of the Project are substantially the same as when Final EIR No. 583 and Final Supplemental EIS/EIR No. 583 were adopted, and Final EIR No. 583 and Final Supplemental EIS/EIR No. 583 adequately addressed the effects of the proposed condemnation action. No substantial changes have been made in the Project, no substantial changes have occurred in the circumstances under which the Project is being undertaken, and no new information of substantial importance to the Project which was not known or could not have been known when the prior Final EIR No. 583 and Final Supplemental EIS/EIR No. 583 were certified has become known in relation to this proposed condemnation action. Thus, no further CEQA review is required.
- b. Final EIR No. 583 and Final Supplemental EIS/EIR No. 583 are adequate to satisfy the requirements of CEQA for the proposed condemnation action.
- c. All mitigation measures are fully enforceable pursuant to CEQA, Public Resources Code Section 21081.6(b), and have either been adopted as conditions, incorporated as part of the Project design, or included in the procedures of the Project Implementation.

Because the requested action would merely accomplish a property acquisition through condemnation proceedings, in accordance with the CEQA Guidelines and the previously certified CEQA documents for the project, which reflect the independent judgment of the Lead Agency, the proposed Project is recommended for approval.

Public Hearing on the Proposed Adoption of a Resolution of Necessity for Condemnation of Real Property Interests for the Prado Dam Project; All Districts (Board of Supervisors' Meeting Date: March 9, 2021) Parcel Nos. E01 PD 24-009, 24-011
 February 24, 2021
 Page 4 of 4

6. General Plan (Government Code Section 65402).

A conformity statement for the Project was requested from the City of Chino ("City") as required by the Code. The City did not respond within 40 days and therefore the Project is deemed to be in conformance per code section 65402.

D. Other Considerations:

1. Compliance with County's Hazardous Materials Assessment (HMA) Policy.

A Hazardous Materials Assessment was initiated by the District and a memo dated September 4, 2020 from North OC Watershed Management Area was received, recommending District proceed with the acquisition subject to the review of a Transfer Disclosure Statement (TDS) from the Owner. The Owner has yet to provide the TDS.

2. Funds.

Your Board is asked to authorize counsel to obtain an Order of Possession for the Parcel. Your Board is also requested to authorize counsel to make a deposit of estimated just compensation in the amount of \$232,500.00 which is based on the appraisal previously obtained and will be paid from Fund 404-080-404-LS43-4100, Job No ESP2134.

3. Relocation Assistance.

The District anticipates that the acquisition of a flowage easement over a portion of this Parcel will not displace any occupants. Therefore, at this time the District has not assigned a Relocation Consultant to this acquisition. If the District later discovers there will be displacement as a result of this acquisition, a Relocation Company will be assigned to explain the Relocation Assistance Program to the Owner and any tenants or occupants remaining onsite ("Claimants") within 60 days after the offer to purchase is accepted as required by law. The District will coordinate with the relocation consultant firm to ensure that relocation benefits, if any, are provided to eligible Claimants upon obtaining an Order of Possession or at acquisition by settlement and/or by court order.

Recommended Actions:

Accordingly, we respectfully recommend that your Board, acting in the capacity as the governing Board of the District, at the conclusion of the public hearing noticed by the Clerk of the Board, adopt, by at least a two-thirds vote of the Board, the proposed Resolution of Necessity and take the following actions:

1. Make the required Findings described above and stated therein;
2. Direct County Counsel and/or previously approved special litigation counsel, Burke, Williams & Sorensen, LLP, to institute eminent domain proceedings to condemn and acquire the Subject Property Interests; and
3. Authorize the Auditor-Controller to encumber and disburse funds as described in the proposed Resolution.

Should you have further questions, please contact me at (714) 667-9700.

Real Property Acquisition Questionnaire* for ASR
(*Applies to property purchase, or acquisition lease, license or easement)

Instructions:

- This questionnaire was developed with input from Auditor Controller, Internal Auditor and CEO Real Estate to assure that County leadership is fully informed.
- Insert the complete answer after each question below.
- When completed, save and include as an Attachment to your ASR.
- In the body of the ASR focus on the considerations relevant to the decision.
- If you need assistance, please contact CEO Real Estate.

1. What property interest is being considered for acquisition (fee, lease, license, easement)?
 - a) Why is this property being considered for acquisition? *It is required for the Prado Dam Project*
 - b) How and who identified this property for a potential acquisition? *Army Corps of Engineers requires acquisition of all property below the 566-inundation line*
 - c) What factors are key in recommending this property for acquisition? *This property is below the 566-inundation line.*
 - d) How does the proposed acquisition fit into the County's/District's strategic or general plan? *It is part of the Prado Dam Project*
 - e) What are the short and long term anticipated uses of the property? *Open space for flowage of flood waters.*
 - f) Are there any limitations on the use of the property for its intended purposes? *No.*
2. What analysis has been performed as to whether to acquire the proposed real property interest?
 - a) Have there been any internally or externally prepared reports regarding this property acquisition? *Yes.*
 - b) Who performed the analysis? *Army Corps of Engineers and Flood Engineers.*
 - c) Provide details about the analysis and cost/benefit comparison. *The Project and required acquisition are necessary to avoid loss of property and/or life in the event of a major storm/flood event.*
3. How was the acquisition price, or lease/license rent, determined? *By an appraisal.*
 - a) Who performed the appraisal or market study and what certifications do they possess? *A third-party independent MAI appraiser. A second appraiser then performed a review of the appraisal.*
 - b) How does the price/rent compare with comparable properties? *It is comparable.*
 - c) Does the setting of the price/rent follow industry standards and best practices? *Yes.*
 - d) What are the specific maintenance requirements and other costs within the agreement and who is responsible? *The County will be responsible for maintenance of full fee acquisitions, primary consisting of weed control and fencing. The property owners will continue to maintain the property in instances where we obtain an easement. Provide an estimate of the costs to the County/District if applicable. Unknown.*
4. What additional post-acquisition remodeling or upgrade costs will be needed for the property to meet its intended use? *Some demolition may be required.*
 - a) Will any of the upgrades be required to meet County, ADA, or other standards and requirements? *N/A.*
 - b) Include estimates of the costs. *Unknown.*
 - c) What department will be responsible for the costs? *Flood.*
5. Can the County terminate the purchase/easement, lease/license? *Yes prior to conclusion of the lawsuit.*
 - a) What would be necessary to terminate the agreement, and when can it be terminated? *A dismissal through the court.*

Attachment C

- b) Are there penalties to terminate the purchase/easement, or lease/license? **We may have to pay the owners legal fees if we decide not to proceed.**
6. What department will be responsible for the acquisition payments? **Flood.**
- a) Are the acquisition costs budgeted in the department's budget? **Yes.**
- b) What fund number will the funds for the acquisition ultimately be drawn from? **Fund 404.**
- c) Will any restricted funds be used for the acquisition? (Check with the Auditor Controller's General Accounting Unit and Counsel if you have questions about whether restricted funds are involved.) **N/A.**
- d) If restricted funds will be used, has County Counsel advised that this is an allowable use of the proposed restricted funds? **N/A.**
7. Does the proposed purchase/lease/license/easement agreement comply with the CEO Real Estate standard language? **Yes.**
- a) List any modified clauses and reasons for modification.

Attachment C

8. If this is a lease, is it a straight lease, an operating lease, a lease with an option to purchase, or a capital lease (see details below)? **N/A**

Capital Lease Determination: At the inception of any *potential* capital lease, it is important to contact the Auditor-Controller's Capital Asset Unit for further guidance to ensure that proper classification and accounting for the lease occurs. There are specialized accounting rules and required forms for capital leases. See further details in the County's Accounting Manual, Policy No. FA-1: *Accounting for Lease Purchases (Capital Leases)*, located on the intranet. For accounting purposes only, a capital lease exists if ANY one (1) of the following four (4) criteria is met:

- i) Lease transfers ownership to the County by the end of the term.
- ii) Lease contains an option to purchase the property by the end of the term for a price lower than the expected fair market value of the property? (For example \$1 or \$1,000, and based on this option price, for accounting purposes only, the ultimate purchase of the property is deemed reasonably assured at the inception of the lease.)
- iii) Lease term is equal to 75% or more of the remaining estimated useful life of the leased property.*
- iv) Present value of the minimum lease payments is equal to 90% or more of the fair value of the property at the inception of the lease.*

*Criteria iii) and iv) don't apply if the lease term begins in the last 25% of a property's estimated useful life.

To validate whether a lease is a capital lease for accounting purposes, please contact the Auditor-Controller's Capital Asset Unit at capitalassets@ac.ocgov.com .

<https://ocgov.box.com/s/f9a51iy16c9y25msu4b03ngxq13p4kng>

**RESOLUTION OF THE BOARD OF SUPERVISORS OF ORANGE COUNTY,
CALIFORNIA, ACTING AS THE GOVERNING BOARD OF THE ORANGE COUNTY
FLOOD CONTROL DISTRICT, DETERMINING THE NECESSITY OF ACQUISITION
BY EMINENT DOMAIN OF REAL PROPERTY**

April 13, 2021

WHEREAS, this Resolution of Necessity (“Resolution”) seeks to acquire property interests in the real property currently owned by Henry Cruz and Joe Cruz, as tenants in common (“Owner”) and located Pomona Rincon Road and State Route 71 in the City of Chino, County of San Bernardino, California, and whereas the property interests to be acquired (“Subject Property Interests”) consist of:

A perpetual right, power, privilege and easement in, on, over, under, and across the surface of that real property legally described by Exhibit A and depicted on Exhibit B to the proposed Resolution, consisting of project parcel no. E01PD-24-009, which is a portion of San Bernardino County Assessor’s Parcel Number (“APN”) 1057-263-02, located at Pomona Rincon Road and State Highway 71, Chino, California (the “Easement Area”), to overflow, flood and/or submerge such real property including the right to cause, without limitation, erosion and/or deposition and associated damages to said Easement Area and any and all structures and improvements situated thereon, in connection with the operation, maintenance, repair, rehabilitation, restoration and improvement of the Prado Dam and reservoir/basin, together with all right, title and interest in and to the structures and improvements now situated on said Easement Area. No structures for human habitation shall be constructed or maintained on the Easement Area. No other structures shall be constructed or maintained within the Easement Area, except as may be approved in writing by the authorized representative of the easement holder. No excavation, drilling or mining shall be conducted, and no landfill placed on the Easement Area without easement holder approval as to the location and method of excavation, drilling, mining, and/or placement of landfill. The Subject Property Interests are subject to existing easements for public roads and highways, public utilities, railroads and pipelines; reserving, however, to underlying fee owner all such rights and privileges as may be used without abridging the rights and easement

Resolution No. _____, Item No. ____
Santa Ana River Mainstem/Prado Dam Project
Acquisition by Eminent Domain of Real Property for Flood Control Purposes

hereby acquired, and provided that any use of the Easement Area shall be subject to all applicable laws including, but not limited, to laws regarding the environment.

WHEREAS, on or before March 30, 2021, pursuant to the requirements of California Code of Civil Procedure section 1245.235, the Clerk of the Board (“Clerk”) mailed notice to the Owner, *inter alia*, at the address shown by the last equalized San Bernardino County assessment roll, of the intention of the Orange County Board of Supervisors (“Board”), acting in its capacity as the governing board of the District, to adopt this Resolution to acquire the Subject Property Interests for purposes of the District’s Santa Ana River Mainstem/Prado Dam Project (“Project”), through eminent domain proceedings, and of the date set for a hearing thereon of April 13, 2021;

WHEREAS, said notice by the Clerk notified the Owner of its right to appear and to be heard at a April 13, 2021, hearing before the Board on the following matters: (a) whether the public interest and necessity require the Project; (b) whether the Project is planned or located in the manner that will be most compatible with the greatest public good and the least private injury; (c) whether the Subject Property Interests sought to be acquired are necessary for the Project; and (d) whether the offer required by section 7267.2 of the Government Code has been made to the owner(s) of record;

WHEREAS, on April 13, 2021, the Board conducted a public hearing and heard and considered public comments, if any, and evidence presented, regarding the Project and regarding the proposed eminent domain acquisition of the Subject Property Interests; and,

WHEREAS, at the close of the public hearing and after the opportunity for open and public discussion among the Board, the Board voted, by more than the statutorily required two-

Resolution No._____, Item No._____
 Santa Ana River Mainstem/Prado Dam Project
 Acquisition by Eminent Domain of Real Property for Flood Control Purposes

thirds' majority of the Board membership, to adopt this Resolution to acquire the Subject Property Interests necessary for the Project through eminent domain proceedings.

NOW, THEREFORE, after consideration of the information contained above as well as in the April 13, 2021, Supplemental Agenda Staff Report,

IT IS HEREBY RESOLVED that this Board finds and determines as follows:

1. Under the California Environmental Quality Act ("CEQA"):
 - a. Final Environmental Impact Report No. 583 (Final EIR No. 583) was previously certified on November 28, 1989, and reflects the independent judgment of the Orange County Flood Control District (District) as Lead Agency. Final Supplemental Environmental Impact Statement/Environmental Impact Report No. 583 (Final Supplemental EIS/EIR No. 583) was previously certified by the Orange County Planning Commission on December 19, 2001, and reflects the independent judgment of the Orange County Planning Commission as Lead Agency. Final EIR No. 583 and Final Supplemental EIS/EIR No. 583 adequately addressed and fully analyzed project environmental impacts for the Santa Ana River Mainstem Project, as well as the Prado Dam Project, which is a necessary and contemplated element of the Santa Ana River Mainstem Project. Both the Final EIR No. 583 and the Final Supplemental EIR/EIS No. 583 are complete and adequately satisfy the requirements of CEQA for the Santa Ana River Mainstem Project, which includes the Prado Dam Project.
 - b. The circumstances of the Project are substantially the same as when Final EIR No. 583 and Final Supplemental EIS/EIR No. 583 were certified, and Final EIR No. 583 and Final Supplemental EIS/EIR No. 583 adequately addressed the effects of the proposed Project. No substantial changes have been made in the Project, no substantial changes have occurred in the circumstances under which the Project is being undertaken and no new information of substantial importance to the Project that was not known or could not have been known when the Final EIR No. 583 and Final Supplemental EIS/EIR No. 583 were certified has become known in relation to these proposed condemnation actions. Thus, no further CEQA review is required.
 - c. Final EIR No. 583 and Final Supplemental EIS/EIR No. 583 are adequate to satisfy the requirements of CEQA for the proposed condemnation actions.
 - d. All mitigation measures are fully enforceable pursuant to CEQA, Public Resources Code Section 21081.6(b), and have either been adopted as conditions, incorporated as part of the Project design or included in the procedures of Project implementation.

Resolution No. _____, Item No. ____
 Santa Ana River Mainstem/Prado Dam Project
 Acquisition by Eminent Domain of Real Property for Flood Control Purposes

2. Direct and authorize County Counsel and/or outside eminent domain counsel, the firm of Burke, Williams & Sorensen, LLP pursuant to its existing contract with the District, to initiate condemnation proceedings to condemn the following interest in real property. Permanent flowage easement interest in real property referred to by the District as Project Parcel No. E01PD-24-009, which covers portions of San Bernardino County Assessor's Parcel No[s]. 1057-263-02.

3. Direct and authorize the Auditor-Controller, upon request by County Counsel, to encumber funds and transfer estimated compensation to the State Treasurer's Condemnation Deposits Fund, in amounts to be specified by County Counsel, in a total amount up to \$182,000, Job No ESP2134; to be paid from Fund 404-080-404-LS43-4100-ESP2134.

4. The public interest and necessity require the Project for the purposes specified by California uncodified Water Code, Act 5682, section 2, also referred to as Water Code App. Sections 36-1 et seq. (the "Orange County Flood Control Act"), including but not limited to the control of flood and storm waters in order to protect the safety, health and welfare of residents and properties within the County of Orange from the potentially devastating effects of a 190-year flood/storm event.

5. The District is authorized to acquire the Subject Property Interests and to exercise the power of eminent domain for the public uses set forth herein under the California Constitution, the California eminent domain law (Code of Civil Procedure Sections 1230.010 et seq., and 1240.010 et seq., including without limitation Section 1240.110), Government Code Section 25350.5, and the Orange County Flood Control Act. The Subject Property Interests are located in San Bernardino County and the District is exercising its power of eminent domain

Resolution No. _____, Item No. ____
Santa Ana River Mainstem/Prado Dam Project
Acquisition by Eminent Domain of Real Property for Flood Control Purposes

extraterritorially pursuant to, *inter alia*, Sections 2 and 16 of the Orange County Flood Control Act.

6. The Project, which will raise the Prado Dam flood basin and expand the potential inundation area up to 566 feet above sea level, is planned and located in the manner that will be the most compatible with the greatest public good and least private injury.

7. The Subject Property Interests are necessary for the Project. It is necessary that the District acquire the Subject Property Interests to carry out the Project's essential flood control purposes. If the Subject Property Interests were not acquired, the Project could not proceed as planned, which in turn would result in inadequate flood protection downstream of the Prado Dam, potential flooding of, or damage to, State Route 91, and a significant risk of property damage, personal injury, and/or loss of life suffered by those downstream in Orange County.

8. The Subject Property Interests will be used for the Project, which constitutes a valid public use. Therefore, the Subject Property Interests will in fact be a public use.

9. In conformance with Sections 7267.1 and 7267.2 of the California Government Code and Board of Supervisors Resolution 67-612, an appraisal was prepared covering the Subject Property Interests. An offer based on said appraisal was made to the Owner of the Subject Property Interests, and a written statement showing the appraised value of the Subject Property Interests and summarizing the basis of that valuation was also delivered to the Owner.

10. The necessary notice of hearing on this Resolution has been given, as required by Code of Civil Procedure section 1245.235.

11. To the extent the Subject Property Interests are already devoted to a public use, the use of the Subject Property Interests for the District's Project is a compatible use that

Resolution No. _____, Item No. ____
Santa Ana River Mainstem/Prado Dam Project
Acquisition by Eminent Domain of Real Property for Flood Control Purposes

will not unreasonably interfere with or impair the continuance of the public use as it presently exists or may reasonably be expected to exist in the future (California Code of Civil Procedure Section 1240.510), or the use of the Subject Property Interests for the Project is a more necessary public use than is the presently existing public use (California Code of Civil Procedure Section 1240.610).

IT IS FURTHER RESOLVED that the Subject Property Interests be acquired by the District, and that the County Counsel of the County of Orange and/or outside counsel, Burke, Williams & Sorensen, LLP, pursuant to its existing contract with the District as previously authorized by this Board for purposes of representing the District in condemnation matters (collectively, “District’s Counsel”), are hereby directed and authorized to institute eminent domain proceedings for the foregoing acquisition, to do, perform, and carry out all necessary proceedings and steps incident to acquiring the Subject Property Interests, to correct any errors or to make or agree to non-material changes in the legal description of the Subject Property Interests as may be necessary for the conduct of the action or other proceedings or transactions required to acquire the Subject Property Interests, and to seek and obtain an order for prejudgment possession of some or all of the Subject Property Interests at such time as District’s Counsel deems it to be necessary and appropriate.

IT IS FURTHER RESOLVED that the Orange County Auditor-Controller is directed and authorized to encumber required funds and to issue funds, as necessary and requested by County Counsel, in the amount of up to the total estimated fair market value of the Subject Property Interests as of the date of value of the appraisal, which was the basis of the purchase offer made to the owner; and to encumber such additional funds, and issue such additional funds

Resolution No. _____, Item No. ____
 Santa Ana River Mainstem/Prado Dam Project
 Acquisition by Eminent Domain of Real Property for Flood Control Purposes

as may be requested by County Counsel, and as necessary to satisfy any court orders for higher deposits or payment of greater compensation, and as necessary to pay for title insurance and other fees following transfer of ownership of the Subject Property Interests to the District. Using those encumbered funds and the funds issued by the Auditor-Controller, District's Counsel are hereby directed and authorized to make deposits of estimated compensation with the State Treasury's Condemnation Deposits Fund in an amount up to \$182,000.

IT IS FURTHER RESOLVED that this Resolution shall be effective immediately upon its adoption, and that the Clerk of the Board shall certify the adoption of this Resolution and certify this record to be a full true, correct copy of the action taken.

Resolution No._____, Item No.____
Santa Ana River Mainstem/Prado Dam Project
Acquisition by Eminent Domain of Real Property for Flood Control Purposes

EXHIBIT A**LEGAL DESCRIPTION**

Santa Ana River – Prado Dam Basin

Facility No: E01PD

Parcel No.: 24-009

PARCEL 1:

That portion of Fractional Section 7, Township 3 South, Range 7 West, San Bernardino Meridian, in the City of Chino Hills, County of San Bernardino, State of California, according to the United States Government Township Plat thereof, described in a Director's Deed recorded February 1, 1973 in Book 8112, Page 1042 of Official Records in the office of the County Recorder of said County described as follows:

BEGINNING at the northerly terminus of that certain course described in said Director's Deed as having a bearing of North 01°50'15" East and a length of 1529.69 feet in the East line of the Northwest Quarter of said Section 7, said east line being the easterly line of land described in said Director's Deed;

thence along said east line, South 01°49'47" West 148.37 feet;

thence leaving said east line, North 60°51'54" West 216.20 feet;

thence South 72°54'09" West 98.98 feet;

thence North 80°59'55" West 128.96 feet;

thence South 59°16'15" West 134.65 feet;

thence South 77°18'10" West 39.07 feet to a point on the westerly line of the land described in said Director's Deed, said point being the southerly terminus of a curve tangent to that certain course described in said Director's deed as having a bearing of "South 02°27'08" West 70.67 feet" from a point described as Point "A" in said Director's Deed, concave easterly and having a radius of 1500 feet, through a central angle of 01°43'11", a distance of 45.02 feet, a radial bearing to said point bears South 89°18'39" East;

thence along said curve northerly, having a radius of 1500 feet concave easterly, said curve also being the westerly line of land described in said Directors Deed, through a central angle of 01°43'11", a distance of 45.02 feet;

thence continuing along said westerly line North 02°24'32" East 52.41 feet to a point on the general northerly line of land described in said Director's Deed;

thence leaving said westerly line along the general northerly line of said Director's Deed the following eight (8) courses:

1) South 66°15'43" East 22.72 feet;

2) North 72°44'27" East 248.93 feet;

- 3) North 22°23'37" East 167.56 feet;
- 4) North 46°20'57" East 63.49 feet;
- 5) North 71°35'47" East 82.54 feet;
- 6) South 51°15'33" East 51.82 feet;
- 7) South 04°13'17" West 156.17 feet;
- 8) South 52°31'43" East 114.00 feet to the **POINT OF BEGINNING**;

Containing an area of 91,526 Square Feet, more or less.

ALL DISTANCES SHOWN ARE GRID, UNLESS OTHERWISE NOTED. DIVIDE A GRID DISTANCE BY 0.99998800 TO OBTAIN A GROUND DISTANCE.

PARCEL 2:

That portion of Fractional Section 7. Township 3 South, Range 7 West, San Bernardino Meridian, in the City of Chino Hills, County of San Bernardino, State of California, according to the United States Government Township Plat thereof, described in a Director's Deed recorded February 1, 1973 in Book 8112, Page 1042 of Official Records in the office of the County Recorder of said County described as follows:

COMMENCING at the northerly terminus of that certain course described in said Director's Deed as having a bearing of North 01°50'15" East and a length of 1529.69 feet in the East line of the Northwest Quarter of said Section 7, said east line being the easterly line of land described in said Director's Deed;;

thence along said east line, South 01°49'47" West 237.11 feet to the **TRUE POINT OF BEGINNING**;

thence continuing along said east line, South 01°49'47" West 306.24 feet;

thence leaving said certain course South 88°52'50" West 67.13 feet;

thence North 77°58'46" West 73.40 feet;

thence North 57°58'19" West 101.56 feet;

thence North 19°04'59" West 46.19 feet;

thence North 52°05'30" East 316.72 feet to the **TRUE POINT OF BEGINNING**.

Containing an area of 45,390 Square Feet, more or less.

ALL DISTANCES SHOWN ARE GRID, UNLESS OTHERWISE NOTED. DIVIDE A GRID DISTANCE BY 0.99998800 TO OBTAIN A GROUND DISTANCE.

PARCEL 3:

That portion of Fractional Section 7. Township 3 South, Range 7 West, San Bernardino Meridian, in the City of Chino Hills, County of San Bernardino, State of California, according to the United States Government Township Plat thereof, described in a Director's Deed recorded February 1, 1973 in Book 8112, Page 1042 of Official Records in the office of the County Recorder of said County described as follows:

COMMENCING at the northerly terminus of that certain course described in said Director's Deed as having a bearing of North 01°50'15" East and a length of 1529.69 feet in the East line of the Northwest Quarter of said Section 7, said east line being the easterly line of land described in said Director's Deed;

thence along said east line, South 01°49'47" West 595.71 feet to the **TRUE POINT OF BEGINNING**;

thence continuing along said east line, South 01°49'47" West 358.91 feet;

thence leaving said east line, South 45°26'34" West 48.10 feet;

thence South 74°55'43" West 62.91 feet;

thence North 70°24'16" West 63.02 feet;

thence North 21°05'17" West 39.51 feet;

thence North 03°54'09" West 161.46 feet;

thence North 45°11'51" East 269.26 feet to the **TRUE POINT OF BEGINNING**.

Containing an area of 53,005 Square Feet, more or less.

ALL DISTANCES SHOWN ARE GRID, UNLESS OTHERWISE NOTED. DIVIDE A GRID DISTANCE BY 0.99998800 TO OBTAIN A GROUND DISTANCE.

PARCEL 4:

That portion of Fractional Section 7. Township 3 South, Range 7 West, San Bernardino Meridian, in the City of Chino Hills, County of San Bernardino, State of California, according to the United States Government Township Plat thereof, described in a Director's Deed recorded February 1, 1973 in Book 8112, Page 1042 of Official Records in the office of the County Recorder of said County described as follows:

BEGINNING at the Southeasterly Corner of land described in said Director's Deed, said corner being the Southerly terminus of that certain course described in said Director's Deed as having a bearing of North 01°50'15" East and a length of 1529.69 feet in the East line of the Northwest Quarter of said Section 7, said east line being the easterly line of land described in said Director's Deed;

thence along said east line, North 01°49'47" East 66.75 feet;

thence leaving said east line North 52°36'45" West 198.09 feet;

thence North 82°05'34" West 35.37 feet to a point on the westerly line of the land described in said Director's Deed, said point being measured along said westerly line a distance of 191.17 feet from the southerly terminus of that certain course described in said Director's Deed as having a bearing of South 19°28'45" East 922.43 feet;

thence along said westerly line South 19°31'25" East 191.17 feet to the southerly terminus of said certain course, said terminus being the southwesterly corner of land described in said Director's Deed and a point on the general southerly line of the land described in said Director's Deed;

thence leaving said westerly line along the general southerly line of said Director's Deed North 53°05'03" East 19.27 feet;

thence continuing along the general southerly line of said Director's Deed South 78°09'54" East 113.40 feet to the **POINT OF BEGINNING**.

Containing an area of 18,469 Square Feet, more or less.

ALL DISTANCES SHOWN ARE GRID, UNLESS OTHERWISE NOTED. DIVIDE A GRID DISTANCE BY 0.99998800 TO OBTAIN A GROUND DISTANCE.

See EXHIBIT B attached and by reference made a part hereof.

APPROVED

Kevin Hills, County Surveyor, L.S. 6617

_____ Date: 9-2-2020

By: Wade Douglas Weaver, L.S. 4337





STATE HIGHWAY 83

N. LINE OF FRAC.
S7-T3S-R7W, SBB&M

N. 1/4 COR OF FRAC.
S7-T3S-R7W, SBB&M

APN:
1057-263-04

APN:
1057-263-03

E. LINE OF FRAC.
S7-T3S-R7W, SBB&M

PARCEL 1

DIRECTOR'S DEED

E01PD-24-009

PARCEL
2

8112-1042 O.R.

APN:
1057-263-02

PARCEL
3

STATE HIGHWAY 71

RANCHO

EL RINCON

PARCEL
4

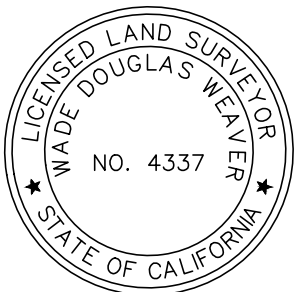

OC PUBLIC WORKS
OC SURVEY
RIGHT-OF-WAY SERVICES

ROW ID NO. 2016-072

SCALE: 1"=80'

EXHIBIT B
SHEET 1 OF 5

PROJECT: PRADO BASIN PARCEL 24-009

PREPARED BY:
Page 12 of 16 J. MORENO

SKETCH TO ACCOMPANY LEGAL DESCRIPTION



N. LINE OF FRAC.
S7-T3S-R7W, SBB&M

N. 1/4 COR OF FRAC.
S7-T3S-R7W, SBB&M

FR. S7
T3S, R7W
SBB&M

GENERAL N'LY LINE OF
DIRECTOR'S DEED 8112-1042 O.R.

APN:
1057-263-03

E01PD-24-009
PARCEL 1

POINT "A" PER DIRECTOR'S DEED
8112-1042 O.R.

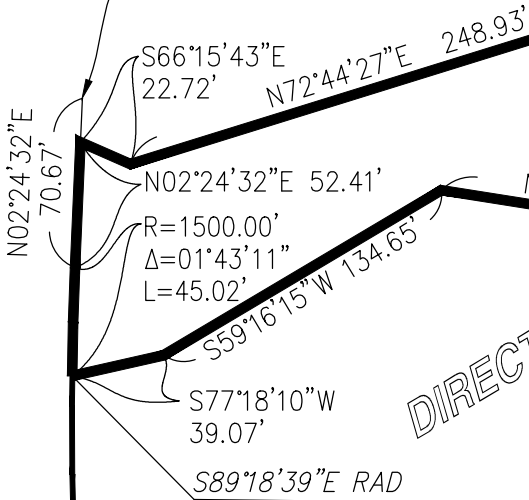

DEED

POB

DIRECTOR'S

APN:
1057-263-02

8112-1042 O.R.

W'LY LINE OF DIRECTOR'S DEED
8112-1042 O.R.

E. LINE OF FRAC.
S7-T3S-R7W, SBB&M

SEE SHEET 3

() PER DIRECTOR'S DEED IN BOOK 8112, PAGE 1042 O.R.

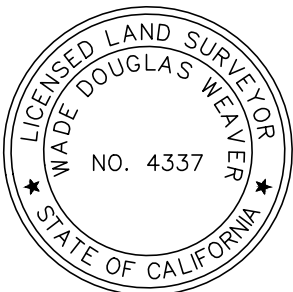

OC PUBLIC WORKS
OC SURVEY
RIGHT-OF-WAY SERVICES

ROW ID NO. 2016-072

SCALE: 1"=80'

EXHIBIT B
SHEET 2 OF 5

PROJECT: PRADO BASIN PARCEL 24-009

PREPARED BY:
Page 13 of 16 J. MORENO



SEE SHEET 2

GENERAL N'LY LINE OF DIRECTOR'S DEED 8112-1042 O.R.

DIRECTOR'S DEED 8112-1042 O.R.

FR. S7 T3S, R7W SBB&M

E01PD-24-009 PARCEL 2

N19°04'59"W 46.19'

APN: 1057-263-02

N57°58'19"W 101.56'

N77°58'46"W 73.40'

S88°52'50"W 67.13'

S01°49'47"W

306.24'

(N01°50'15"E 1529.69')

237.11'

S01°49'47"W

E. LINE OF FRAC. S7-T3S-R7W, SBB&M

POC

TPOB

SEE SHEET 4

() PER DIRECTOR'S DEED IN BOOK 8112, PAGE 1042 O.R.

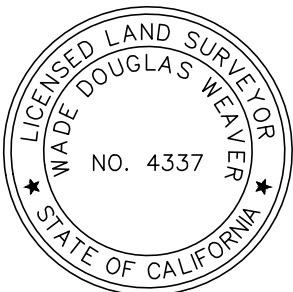

OC PUBLIC WORKS
OC SURVEY
RIGHT-OF-WAY SERVICES

ROW ID NO. 2016-072

SCALE: 1"=80'

EXHIBIT B
SHEET 3 OF 5

PROJECT: PRADO BASIN PARCEL 24-009

PREPARED BY:
Page 14 of 16 J. MORENO

SEE SHEET 3

GENERAL N'LY LINE OF DIRECTOR'S DEED 8112-1042 O.R.



DIRECTOR'S DEED
8112-1042 O.R.

APN:
1057-263-02

FR. S7
T3S, R7W
SBB&M

E01PD-24-009
PARCEL 3

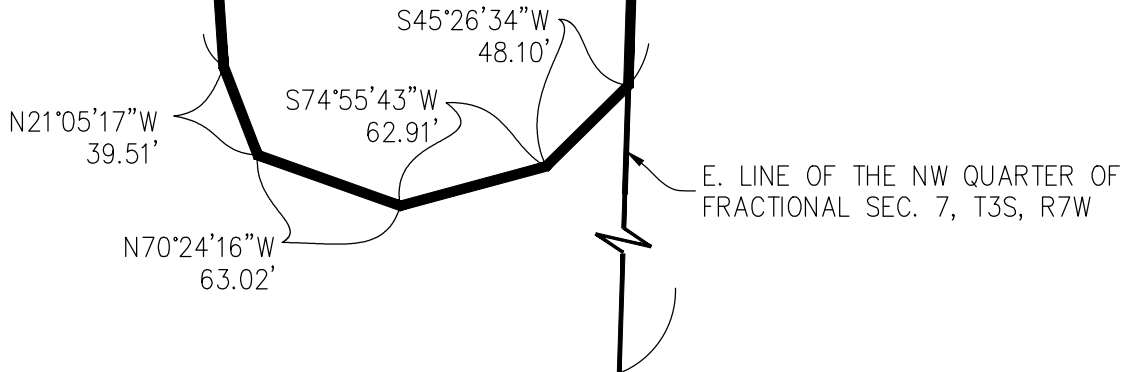

POC

TPOB

E. LINE OF THE NW QUARTER OF FRACTIONAL SEC. 7, T3S, R7W

SEE SHEET 5

() PER DIRECTOR'S DEED IN BOOK 8112, PAGE 1042 O.R.

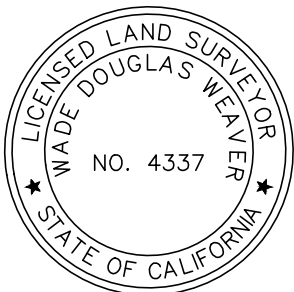

OC PUBLIC WORKS
OC SURVEY
RIGHT-OF-WAY SERVICES

ROW ID NO. 2016-072

SCALE: 1"=80'

EXHIBIT B
SHEET 4 OF 5

PROJECT: PRADO BASIN PARCEL 24-009

PREPARED BY:
Page 15 of 16 J. MORENO



SEE SHEET 4

GENERAL N'LY LINE OF DIRECTORS DEED 8112-1042 O.R.

DIRECTORS DEED 8112-1042 O.R.

APN:

1057-263-02

W'LY LINE OF DIRECTOR'S DEED. 8112-1042 O.R.

STATE HIGHWAY 71
(S19°28'45"E
922.43')

N82°05'34"W
35.37'

FR. S7
T3S, R7W
SBB&M

N52°36'45"W
198.09'

E01PD-24-009
PARCEL 4

191.17'

S19°31'25"E
922.43')

S78°09'54"E
113.40'

N53°05'03"E
19.27'

APN:

1057-263-05

GENERAL S'LY LINE OF DIRECTORS DEED 8112-1042 O.R.

(N01°50'15"E 1529.69')

E. LINE OF THE NW QUARTER OF FRACTIONAL SEC. 7, T3S, R7W

POB

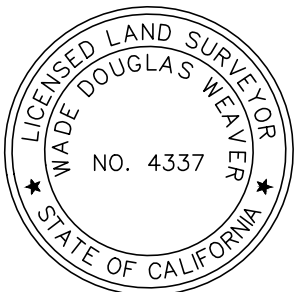

() PER DIRECTOR'S DEED IN BOOK 8112, PAGE 1042 O.R.



OC PUBLIC WORKS
OC SURVEY
RIGHT-OF-WAY SERVICES

ROW ID NO. 2016-072

SCALE: 1"=80'

EXHIBIT B
SHEET 5 OF 5

PROJECT: PRADO BASIN PARCEL 24-009

PREPARED BY:
Page 16 of 16 J. MORENO

**RESOLUTION OF THE BOARD OF SUPERVISORS OF ORANGE COUNTY,
CALIFORNIA, ACTING AS THE GOVERNING BOARD OF THE ORANGE COUNTY
FLOOD CONTROL DISTRICT, DETERMINING THE NECESSITY OF ACQUISITION
BY EMINENT DOMAIN OF REAL PROPERTY**

April 13, 2021

WHEREAS, this Resolution of Necessity (“Resolution”) seeks to acquire property interests in the real property currently owned by Henry Cruz and Virginia Cruz, as tenants in common (“Owner”) and located Pomona Rincon Road and State Route 71, in the City of Chino, County of San Bernardino, California, and whereas the property interests to be acquired (“Subject Property Interests”) consist of:

A perpetual right, power, privilege and easement in, on, over, under, and across the surface of that real property legally described by Exhibit A and depicted on Exhibit B to the proposed Resolution, consisting of project parcel no. E01PD-24-011, which is a portion of San Bernardino County Assessor’s Parcel Number (“APN”) 1057-263-04, located at Pomona Rincon Road and State Highway 71, Chino, California(the “Easement Area”), to overflow, flood and/or submerge such real property including the right to cause, without limitation, erosion and/or deposition and associated damages to said Easement Area and any and all structures and improvements situated thereon, in connection with the operation, maintenance, repair, rehabilitation, restoration and improvement of the Prado Dam and reservoir/basin, together with all right, title and interest in and to the structures and improvements now situated on said Easement Area. No structures for human habitation shall be constructed or maintained on the Easement Area. No other structures shall be constructed or maintained within the Easement Area, except as may be approved in writing by the authorized representative of the easement holder. No excavation, drilling or mining shall be conducted, and no landfill placed on the Easement Area without easement holder approval as to the location and method of excavation, drilling, mining, and/or placement of landfill. The Subject Property Interests are subject to existing easements for public roads and highways, public utilities, railroads and pipelines; reserving, however, to underlying fee owner all such rights and privileges as may be used without abridging the rights and easement

Resolution No._____, Item No._____
Santa Ana River Mainstem/Prado Dam Project
Acquisition by Eminent Domain of Real Property for Flood Control Purposes

hereby acquired, and provided that any use of the Easement Area shall be subject to all applicable laws including, but not limited, to laws regarding the environment.

WHEREAS, on or before March 30, 2021 pursuant to the requirements of California Code of Civil Procedure section 1245.235, the Clerk of the Board (“Clerk”) mailed notice to the Owner, *inter alia*, at the address shown by the last equalized San Bernardino County assessment roll, of the intention of the Orange County Board of Supervisors (“Board”), acting in its capacity as the governing board of the District, to adopt this Resolution to acquire the Subject Property Interests for purposes of the District’s Santa Ana River Mainstem/Prado Dam Project (“Project”), through eminent domain proceedings, and of the date set for a hearing thereon of April 13, 2021;

WHEREAS, said notice by the Clerk notified the Owner of its right to appear and to be heard at a April 13, 2021, hearing before the Board on the following matters: (a) whether the public interest and necessity require the Project; (b) whether the Project is planned or located in the manner that will be most compatible with the greatest public good and the least private injury; (c) whether the Subject Property Interests sought to be acquired are necessary for the Project; and (d) whether the offer required by section 7267.2 of the Government Code has been made to the owner(s) of record;

WHEREAS, on April 13, 2021, the Board conducted a public hearing and heard and considered public comments, if any, and evidence presented, regarding the Project and regarding the proposed eminent domain acquisition of the Subject Property Interests; and,

WHEREAS, at the close of the public hearing and after the opportunity for open and public discussion among the Board, the Board voted, by more than the statutorily required two-

Resolution No._____, Item No._____
 Santa Ana River Mainstem/Prado Dam Project
 Acquisition by Eminent Domain of Real Property for Flood Control Purposes

thirds' majority of the Board membership, to adopt this Resolution to acquire the Subject Property Interests necessary for the Project through eminent domain proceedings.

NOW, THEREFORE, after consideration of the information contained above as well as in the April 13, 2021, Supplemental Agenda Staff Report,

IT IS HEREBY RESOLVED that this Board finds and determines as follows:

1. Under the California Environmental Quality Act ("CEQA"):

a. Final Environmental Impact Report No. 583 (Final EIR No. 583) was previously certified on November 28, 1989, and reflects the independent judgment of the Orange County Flood Control District (District) as Lead Agency. Final Supplemental Environmental Impact Statement/Environmental Impact Report No. 583 (Final Supplemental EIS/EIR No. 583) was previously certified by the Orange County Planning Commission on December 19, 2001, and reflects the independent judgment of the Orange County Planning Commission as Lead Agency. Final EIR No. 583 and Final Supplemental EIS/EIR No. 583 adequately addressed and fully analyzed project environmental impacts for the Santa Ana River Mainstem Project, as well as the Prado Dam Project, which is a necessary and contemplated element of the Santa Ana River Mainstem Project. Both the Final EIR No. 583 and the Final Supplemental EIR/EIS No. 583 are complete and adequately satisfy the requirements of CEQA for the Santa Ana River Mainstem Project, which includes the Prado Dam Project.

b. The circumstances of the Project are substantially the same as when Final EIR No. 583 and Final Supplemental EIS/EIR No. 583 were certified, and Final EIR No. 583 and Final Supplemental EIS/EIR No. 583 adequately addressed the effects of the proposed Project. No substantial changes have been made in the Project, no substantial changes have occurred in the circumstances under which the Project is being undertaken and no new information of substantial importance to the Project that was not known or could not have been known when the Final EIR No. 583 and Final Supplemental EIS/EIR No. 583 were certified has become known in relation to these proposed condemnation actions. Thus, no further CEQA review is required.

c. Final EIR No. 583 and Final Supplemental EIS/EIR No. 583 are adequate to satisfy the requirements of CEQA for the proposed condemnation actions.

d. All mitigation measures are fully enforceable pursuant to CEQA, Public Resources Code Section 21081.6(b), and have either been adopted as conditions, incorporated as part of the Project design or included in the procedures of Project implementation.

Resolution No. _____, Item No. ____
 Santa Ana River Mainstem/Prado Dam Project
 Acquisition by Eminent Domain of Real Property for Flood Control Purposes

2. Direct and authorize County Counsel and/or outside eminent domain counsel, the firms of Burke, Williams & Sorensen, LLP pursuant to its existing contract with the District, to initiate condemnation proceedings to condemn the following interest in real property. Permanent flowage easement interest in real property referred to by the District as Project Parcel No. E01PD-24-011, which covers portions of San Bernardino County Assessor's Parcel No[s]. 1057-263-04.

3. Direct and authorize the Auditor-Controller, upon request by County Counsel, to encumber funds and transfer estimated compensation to the State Treasurer's Condemnation Deposits Fund, in amounts to be specified by County Counsel, in a total amount up to \$50,500, Job No ESP2134; to be paid from Fund 404-080-404-LS43-4100-ESP2134.

4. The public interest and necessity require the Project for the purposes specified by California uncodified Water Code, Act 5682, section 2, also referred to as Water Code App. Sections 36-1 et seq. (the "Orange County Flood Control Act"), including but not limited to the control of flood and storm waters in order to protect the safety, health and welfare of residents and properties within the County of Orange from the potentially devastating effects of a 190-year flood/storm event.

5. The District is authorized to acquire the Subject Property Interests and to exercise the power of eminent domain for the public uses set forth herein under the California Constitution, the California eminent domain law (Code of Civil Procedure Sections 1230.010 et seq., and 1240.010 et seq., including without limitation Section 1240.110), Government Code Section 25350.5, and the Orange County Flood Control Act. The Subject Property Interests are located in San Bernardino County and the District is exercising its power of eminent domain

Resolution No. _____, Item No. ____
 Santa Ana River Mainstem/Prado Dam Project
 Acquisition by Eminent Domain of Real Property for Flood Control Purposes

extraterritorially pursuant to, *inter alia*, Sections 2 and 16 of the Orange County Flood Control Act.

6. The Project, which will raise the Prado Dam flood basin and expand the potential inundation area up to 566 feet above sea level, is planned and located in the manner that will be the most compatible with the greatest public good and least private injury.

7. The Subject Property Interests are necessary for the Project. It is necessary that the District acquire the Subject Property Interests to carry out the Project's essential flood control purposes. If the Subject Property Interests were not acquired, the Project could not proceed as planned, which in turn would result in inadequate flood protection downstream of the Prado Dam, potential flooding of, or damage to, State Route 91, and a significant risk of property damage, personal injury, and/or loss of life suffered by those downstream in Orange County.

8. The Subject Property Interests will be used for the Project, which constitutes a valid public use. Therefore, the Subject Property Interests will in fact be a public use.

9. In conformance with Sections 7267.1 and 7267.2 of the California Government Code and Board of Supervisors Resolution 67-612, an appraisal was prepared covering the Subject Property Interests. An offer based on said appraisal was made to the Owner of the Subject Property Interests, and a written statement showing the appraised value of the Subject Property Interests and summarizing the basis of that valuation was also delivered to the Owner.

10. The necessary notice of hearing on this Resolution has been given, as required by Code of Civil Procedure section 1245.235.

11. To the extent the Subject Property Interests are already devoted to a public use, the use of the Subject Property Interests for the District's Project is a compatible use that will not

Resolution No. _____, Item No. ____
Santa Ana River Mainstem/Prado Dam Project
Acquisition by Eminent Domain of Real Property for Flood Control Purposes

unreasonably interfere with or impair the continuance of the public use as it presently exists or may reasonably be expected to exist in the future (California Code of Civil Procedure Section 1240.510), or the use of the Subject Property Interests for the Project is a more necessary public use than is the presently existing public use (California Code of Civil Procedure Section 1240.610).

IT IS FURTHER RESOLVED that the Subject Property Interests be acquired by the District, and that the County Counsel of the County of Orange and/or outside counsel, Burke, Williams & Sorensen, LLP, pursuant to its existing contract with the District as previously authorized by this Board for purposes of representing the District in condemnation matters (collectively, “District’s Counsel”), are hereby directed and authorized to institute eminent domain proceedings for the foregoing acquisition, to do, perform, and carry out all necessary proceedings and steps incident to acquiring the Subject Property Interests, to correct any errors or to make or agree to non-material changes in the legal description of the Subject Property Interests as may be necessary for the conduct of the action or other proceedings or transactions required to acquire the Subject Property Interests, and to seek and obtain an order for prejudgment possession of some or all of the Subject Property Interests at such time as District’s Counsel deems it to be necessary and appropriate.

IT IS FURTHER RESOLVED that the Orange County Auditor-Controller is directed and authorized to encumber required funds and to issue funds, as necessary and requested by County Counsel, in the amount of up to the total estimated fair market value of the Subject Property Interests as of the date of value of the appraisal, which was the basis of the purchase offer made to the owner; and to encumber such additional funds, and issue such additional funds

Resolution No. _____, Item No. ____
 Santa Ana River Mainstem/Prado Dam Project
 Acquisition by Eminent Domain of Real Property for Flood Control Purposes

as may be requested by County Counsel, and as necessary to satisfy any court orders for higher deposits or payment of greater compensation, and as necessary to pay for title insurance and other fees following transfer of ownership of the Subject Property Interests to the District. Using those encumbered funds and the funds issued by the Auditor-Controller, District's Counsel are hereby directed and authorized to make deposits of estimated compensation with the State Treasury's Condemnation Deposits Fund in an amount up to \$50,500.

IT IS FURTHER RESOLVED that this Resolution shall be effective immediately upon its adoption, and that the Clerk of the Board shall certify the adoption of this Resolution and certify this record to be a full true, correct copy of the action taken.

Resolution No._____, Item No._____
Santa Ana River Mainstem/Prado Dam Project
Acquisition by Eminent Domain of Real Property for Flood Control Purposes

EXHIBIT A**LEGAL DESCRIPTION**

Santa Ana River – Prado Dam Basin

Facility No: E01PD

Parcel No.: 24-011

That portion of Fractional Section 7. Township 3 South, Range 7 West, San Bernardino Meridian, in the City of Chino Hills, County of San Bernardino, State of California, according to the United States Government Township Plat thereof, described in a Director's Deed recorded June 11, 1973 in Book 8201, Page 907 of Official Records in the office of the County Recorder of said County lying northeasterly, easterly and southeasterly of the follow described line:

BEGINNING at the northerly terminus of that certain course described as having a bearing of South 17°43'00" West and a length of 249.17 feet in the westerly line of said Director's Deed, said northerly terminus being a point in the North line of said Fractional Section 7, distant along said North line North 88°50'18" West 519.32 feet from the north quarter corner of said section, said point also being the Northeasterly corner of that certain parcel of land secondly described in Deed to the State of California, in Book 2417 of Official Records, Page 574, in the Office of the County Recorder of said county;

thence along said westerly line of Director's Deed, said line also being the easterly line of said parcel to the State of California, South 17°44'17" West 151.76 feet;

thence leaving said westerly line, South 35°56'23" East 90.17 feet;

thence South 04°04'02" West 95.90 feet;

thence South 19°11'27" West 164.84 feet;

thence South 36°13'20" West 57.44 feet to a point on the westerly line of the land described in said Director's Deed, said point being measured along said westerly line a distance of 114.48 feet from the most southerly corner of said land described in Director's Deed;

thence along said westerly line of the land described in said Director's Deed South 08°02'19" East 114.48 feet to the most southerly corner of said land described in Director's Deed;

thence along the southeasterly, northeasterly and northerly lines of said Director's Deed the following five (5) courses:

- 1) North 31°08'07" East 156.48 feet;
- 2) North 25°04'17" East 312.55 feet;
- 3) North 24°04'23" West 227.70 feet;

4) North 82°57'03" West 26.10 feet to a point on the north line of said section, said point being measured along said north line a distance of 22.34 feet from the northerly terminus of that certain course described as having a bearing of South 17°43'00" West and a length of 249.17 of said Director's Deed;

5) North 88°50'18" West 22.34 feet along said north section line to the **POINT OF BEGINNING**;

Containing an area of 57,853 Square Feet, more or less.

ALL DISTANCES SHOWN ARE GRID, UNLESS OTHERWISE NOTED. DIVIDE A GRID DISTANCE BY 0.9999880 TO OBTAIN A GROUND DISTANCE

See EXHIBIT B attached and by reference made a part hereof.

APPROVED

Kevin Hills, County Surveyor, L.S. 6617



Date: 9/2/2020

By: Wade Douglas Weaver, L.S. 4337

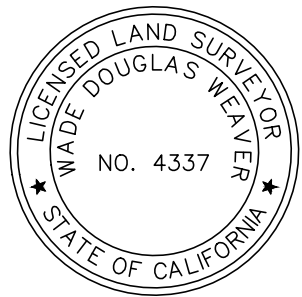
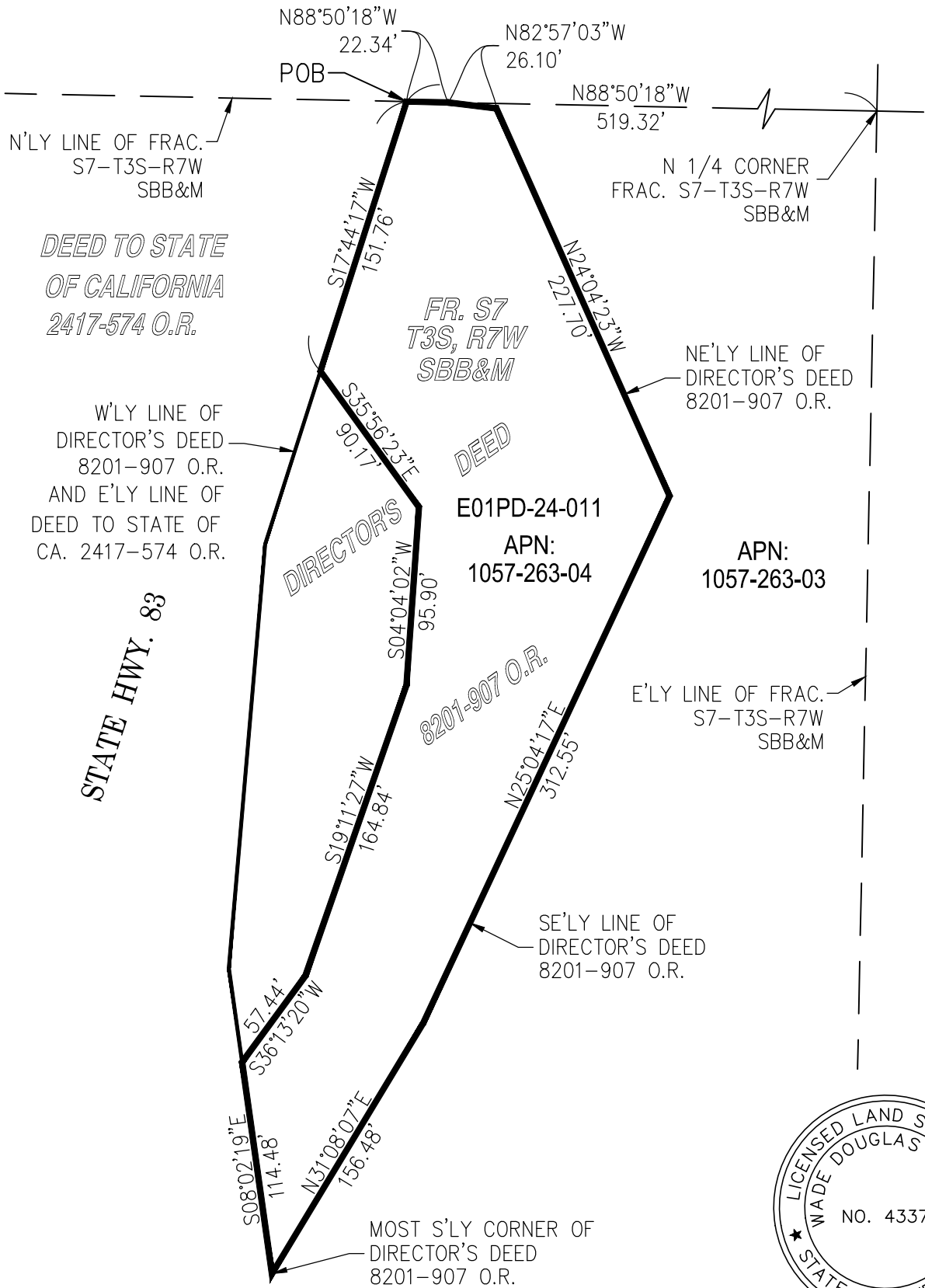

**OC PUBLIC WORKS
OC SURVEY**
RIGHT-OF-WAY SERVICES

ROW ID NO. 2016-072

SCALE: 1"=80'

EXHIBIT B
SHEET 1 OF 1

PROJECT: PRADO BASIN PARCEL 24-011

PREPARED BY:
Page 10 of J. MORENO

**NOTICE OF INTENTION OF THE BOARD OF SUPERVISORS
OF THE COUNTY OF ORANGE, CALIFORNIA, ACTING AS THE
GOVERNING BOARD OF THE ORANGE COUNTY FLOOD CONTROL
DISTRICT, TO CONSIDER FOR ADOPTION A RESOLUTION DETERMINING
THE NECESSITY OF ACQUISITION BY EMINENT DOMAIN OF REAL
PROPERTY**

YOU ARE HEREBY NOTIFIED, pursuant to Code of Civil Procedure section 1245.235, that the Board of Supervisors of the County of Orange (the “Board”), acting as the governing board of the Orange County Flood Control District (the “District”), intends to consider for adoption a resolution of necessity (the “Resolution”), a copy of which as proposed is attached to this Notice, determining the necessity to acquire, through eminent domain proceedings, an easement for flowage purposes over certain real property more specifically described below (the “Subject Property Interests”) – for purposes of the District’s Santa Ana River Mainstem/Prado Dam project (the “Project”). The Subject Property Interests consist of the following:

A perpetual right, power, privilege and easement in, on, over, under, and across the surface of that real property legally described by Exhibit A and depicted on Exhibit B to the proposed Resolution, consisting of project parcel no. E01PD-24-009, which is a portion of San Bernardino County Assessor’s Parcel Number (“APN”) 1057-263-02, located at Pomona Rincon Road and State Route 71, Chino, California (the “Easement Area”), to overflow, flood and/or submerge such real property including the right to cause, without limitation, erosion and/or deposition and associated damages to said Easement Area and any and all structures and improvements situated thereon, in connection with the operation, maintenance, repair, rehabilitation, restoration and improvement of the Prado Dam and reservoir/basin, together with all right, title and interest in and to the structures and improvements now situated on said Easement Area. No structures for human habitation shall be constructed or maintained on the Easement Area. No other structures shall be constructed or maintained within the Easement Area, except as may be approved in writing by the authorized representative of the easement holder. No excavation, drilling or mining shall be conducted, and no landfill placed on the Easement Area without easement

Resolution No._____, Item No.____
Santa Ana River Mainstem/Prado Dam Project
Acquisition by Eminent Domain of Real Property for Flood Control Purposes

holder approval as to the location and method of excavation, drilling, mining, and/or placement of landfill. The Subject Property Interests are subject to existing easements for public roads and highways, public utilities, railroads and pipelines; reserving, however, to underlying fee owner all such rights and privileges as may be used without abridging the rights and easement hereby acquired, and provided that any use of the Easement Area shall be subject to all applicable laws including, but not limited, to laws regarding the environment.

The Subject Property Interests are being considered for acquisition through eminent domain proceedings because District staff believes they are required for the essential flood control purposes of the District with respect to the District's Project; that if the Subject Property Interests were not acquired, the Project could not proceed as planned, which in turn would result in inadequate flood protection downstream of the Prado Dam, potential flooding of, or damage to, State Route 91, and a significant risk of property damage, personal injury and/or loss of life suffered by those downstream in Orange County; and that it is also necessary that the District acquire the Subject Property Interests because that area will itself be exposed to a greater risk of inundation as a result of the increased capacity of the Project reservoir.

YOU ARE HEREBY NOTIFIED that the public hearing by the Board to consider adoption of the Resolution is set for 9:30 a.m. (or as soon thereafter as the Board meeting reaches the agenda item relating to this public hearing) on April 13, 2021, at the Board of Supervisors' Hearing Room, First Floor, County Hall of Administration, 333 W. Santa Ana Blvd., Santa Ana, California.

YOU ARE HEREBY FURTHER NOTIFIED that you must file a written request to appear and be heard within fifteen (15) days of the mailing of this Notice by filing or delivering a written request to the address below if you desire to appear and be

Resolution No._____, Item No.____
 Santa Ana River Mainstem/Prado Dam Project
 Acquisition by Eminent Domain of Real Property for Flood Control Purposes

heard on: (1) whether *the public interest and necessity require the Project*; (2) *whether the Project is planned or located in the manner that will be most compatible with the greatest public good and the least private injury*; (3) *whether the Subject Property Interests sought to be acquired are necessary for the Project*; and (4) *whether the offer required by section 7267.2 of the Government Code has been made to the owner of record.*

Clerk of the Board of Supervisors
Post Office Box 687
Hall of Administration, Fourth Floor
333 W. Santa Ana Blvd.
Santa Ana, California 92702

You may use the following page of this Notice for this purpose to notify the Board of Supervisors of your intent and desire to be heard. Your failure to file a written request to appear and be heard within fifteen (15) days after this Notice was mailed may result by law in a waiver of your right to be heard. For further information, please contact Robin Stieler, Clerk of the Board of Supervisors at (714) 834-3324.

**REQUEST TO BE HEARD ON RESOLUTION DETERMINING THE
NECESSITY TO ACQUIRE AND CONDEMN, THROUGH EMINENT DOMAIN,
REAL PROPERTY FOR THE SANTA ANA RIVER MAINSTEM/ PRADO DAM
PROJECT**

Name _____

Address _____

Telephone Number _____

Dated: _____

(Signature)

Resolution No._____, Item No.____
Santa Ana River Mainstem/Prado Dam Project
Acquisition by Eminent Domain of Real Property for Flood Control Purposes

DECLARATION OF MAILING

_____, Clerk of the Board of Supervisors,
 (Name) (Title)
 on behalf of the County of Orange, CEO Real Estate Department, hereby declares as follows:

That on March 30, 2021, I mailed, postage prepaid, a copy of the attached NOTICE OF INTENTION OF THE BOARD OF SUPERVISORS OF THE COUNTY OF ORANGE, CALIFORNIA, ACTING AS THE GOVERNING BOARD OF THE ORANGE COUNTY FLOOD CONTROL DISTRICT, TO CONSIDER FOR ADOPTION A RESOLUTION DETERMINING THE NECESSITY OF ACQUISITION BY EMINENT DOMAIN OF REAL PROPERTY to the record owner of the real property which may be acquired and whose names and addresses appear on the last equalized assessment rolls. The names and addresses of all persons the attached Notice was mailed to are as follows:

Notice Recipients – Names and Addresses	
	Henry Cruz and Joe Cruz 5865 Panama Drive Buena Park, CA. 90620
	Brad Kuhn, Attorney at Law, Nossaman LLP 18101 Von Karman Avenue, Suite 1800 Irvine, CA 92612

I declare under penalty of perjury under the laws of the State of California that the foregoing is true and correct to the best of my knowledge.

EXECUTED at Santa Ana, California, this ____ day of _____, 2020.

 (Signature)

Resolution No._____, Item No.____
 Santa Ana River Mainstem/Prado Dam Project
 Acquisition by Eminent Domain of Real Property for Flood Control Purposes

EXHIBIT A**LEGAL DESCRIPTION**

Santa Ana River – Prado Dam Basin
 Facility No: E01PD
 Parcel No.: 24-009

PARCEL 1:

That portion of Fractional Section 7, Township 3 South, Range 7 West, San Bernardino Meridian, in the City of Chino Hills, County of San Bernardino, State of California, according to the United States Government Township Plat thereof, described in a Director's Deed recorded February 1, 1973 in Book 8112, Page 1042 of Official Records in the office of the County Recorder of said County described as follows:

BEGINNING at the northerly terminus of that certain course described in said Director's Deed as having a bearing of North 01°50'15" East and a length of 1529.69 feet in the East line of the Northwest Quarter of said Section 7, said east line being the easterly line of land described in said Director's Deed;

thence along said east line, South 01°49'47" West 148.37 feet;

thence leaving said east line, North 60°51'54" West 216.20 feet;

thence South 72°54'09" West 98.98 feet;

thence North 80°59'55" West 128.96 feet;

thence South 59°16'15" West 134.65 feet;

thence South 77°18'10" West 39.07 feet to a point on the westerly line of the land described in said Director's Deed, said point being the southerly terminus of a curve tangent to that certain course described in said Director's deed as having a bearing of "South 02°27'08" West 70.67 feet" from a point described as Point "A" in said Director's Deed, concave easterly and having a radius of 1500 feet, through a central angle of 01°43'11", a distance of 45.02 feet, a radial bearing to said point bears South 89°18'39" East;

thence along said curve northerly, having a radius of 1500 feet concave easterly, said curve also being the westerly line of land described in said Directors Deed, through a central angle of 01°43'11", a distance of 45.02 feet;

thence continuing along said westerly line North 02°24'32" East 52.41 feet to a point on the general northerly line of land described in said Director's Deed;

thence leaving said westerly line along the general northerly line of said Director's Deed the following eight (8) courses:

1) South 66°15'43" East 22.72 feet;

2) North 72°44'27" East 248.93 feet;

- 3) North 22°23'37" East 167.56 feet;
- 4) North 46°20'57" East 63.49 feet;
- 5) North 71°35'47" East 82.54 feet;
- 6) South 51°15'33" East 51.82 feet;
- 7) South 04°13'17" West 156.17 feet;
- 8) South 52°31'43" East 114.00 feet to the **POINT OF BEGINNING**;

Containing an area of 91,526 Square Feet, more or less.

ALL DISTANCES SHOWN ARE GRID, UNLESS OTHERWISE NOTED. DIVIDE A GRID DISTANCE BY 0.99998800 TO OBTAIN A GROUND DISTANCE.

PARCEL 2:

That portion of Fractional Section 7. Township 3 South, Range 7 West, San Bernardino Meridian, in the City of Chino Hills, County of San Bernardino, State of California, according to the United States Government Township Plat thereof, described in a Director's Deed recorded February 1, 1973 in Book 8112, Page 1042 of Official Records in the office of the County Recorder of said County described as follows:

COMMENCING at the northerly terminus of that certain course described in said Director's Deed as having a bearing of North 01°50'15" East and a length of 1529.69 feet in the East line of the Northwest Quarter of said Section 7, said east line being the easterly line of land described in said Director's Deed;;

thence along said east line, South 01°49'47" West 237.11 feet to the **TRUE POINT OF BEGINNING**;

thence continuing along said east line, South 01°49'47" West 306.24 feet;

thence leaving said certain course South 88°52'50" West 67.13 feet;

thence North 77°58'46" West 73.40 feet;

thence North 57°58'19" West 101.56 feet;

thence North 19°04'59" West 46.19 feet;

thence North 52°05'30" East 316.72 feet to the **TRUE POINT OF BEGINNING**.

Containing an area of 45,390 Square Feet, more or less.

ALL DISTANCES SHOWN ARE GRID, UNLESS OTHERWISE NOTED. DIVIDE A GRID DISTANCE BY 0.99998800 TO OBTAIN A GROUND DISTANCE.

PARCEL 3:

That portion of Fractional Section 7. Township 3 South, Range 7 West, San Bernardino Meridian, in the City of Chino Hills, County of San Bernardino, State of California, according to the United States Government Township Plat thereof, described in a Director's Deed recorded February 1, 1973 in Book 8112, Page 1042 of Official Records in the office of the County Recorder of said County described as follows:

COMMENCING at the northerly terminus of that certain course described in said Director's Deed as having a bearing of North 01°50'15" East and a length of 1529.69 feet in the East line of the Northwest Quarter of said Section 7, said east line being the easterly line of land described in said Director's Deed;

thence along said east line, South 01°49'47" West 595.71 feet to the **TRUE POINT OF BEGINNING**;

thence continuing along said east line, South 01°49'47" West 358.91 feet;

thence leaving said east line, South 45°26'34" West 48.10 feet;

thence South 74°55'43" West 62.91 feet;

thence North 70°24'16" West 63.02 feet;

thence North 21°05'17" West 39.51 feet;

thence North 03°54'09" West 161.46 feet;

thence North 45°11'51" East 269.26 feet to the **TRUE POINT OF BEGINNING**.

Containing an area of 53,005 Square Feet, more or less.

ALL DISTANCES SHOWN ARE GRID, UNLESS OTHERWISE NOTED. DIVIDE A GRID DISTANCE BY 0.99998800 TO OBTAIN A GROUND DISTANCE.

PARCEL 4:

That portion of Fractional Section 7. Township 3 South, Range 7 West, San Bernardino Meridian, in the City of Chino Hills, County of San Bernardino, State of California, according to the United States Government Township Plat thereof, described in a Director's Deed recorded February 1, 1973 in Book 8112, Page 1042 of Official Records in the office of the County Recorder of said County described as follows:

BEGINNING at the Southeasterly Corner of land described in said Director's Deed, said corner being the Southerly terminus of that certain course described in said Director's Deed as having a bearing of North 01°50'15" East and a length of 1529.69 feet in the East line of the Northwest Quarter of said Section 7, said east line being the easterly line of land described in said Director's Deed;

thence along said east line, North 01°49'47" East 66.75 feet;

thence leaving said east line North 52°36'45" West 198.09 feet;

thence North 82°05'34" West 35.37 feet to a point on the westerly line of the land described in said Director's Deed, said point being measured along said westerly line a distance of 191.17 feet from the southerly terminus of that certain course described in said Director's Deed as having a bearing of South 19°28'45" East 922.43 feet;

thence along said westerly line South 19°31'25" East 191.17 feet to the southerly terminus of said certain course, said terminus being the southwesterly corner of land described in said Director's Deed and a point on the general southerly line of the land described in said Director's Deed;

thence leaving said westerly line along the general southerly line of said Director's Deed North 53°05'03" East 19.27 feet;

thence continuing along the general southerly line of said Director's Deed South 78°09'54" East 113.40 feet to the **POINT OF BEGINNING**.

Containing an area of 18,469 Square Feet, more or less.

ALL DISTANCES SHOWN ARE GRID, UNLESS OTHERWISE NOTED. DIVIDE A GRID DISTANCE BY 0.99998800 TO OBTAIN A GROUND DISTANCE.

See EXHIBIT B attached and by reference made a part hereof.

APPROVED

Kevin Hills, County Surveyor, L.S. 6617

_____ Date: 9-2-2020

By: Wade Douglas Weaver, L.S. 4337





STATE HIGHWAY 83

N. LINE OF FRAC.
S7-T3S-R7W, SBB&M

N. 1/4 COR OF FRAC.
S7-T3S-R7W, SBB&M

APN:
1057-263-04

APN:
1057-263-03

E. LINE OF FRAC.
S7-T3S-R7W, SBB&M

PARCEL 1

DIRECTOR'S DEED

E01PD-24-009

PARCEL 2

8112-1042 O.R.

APN:
1057-263-02

PARCEL 3

STATE HIGHWAY 71

RANCHO
EL RINCON

PARCEL 4



OC PUBLIC WORKS
OC SURVEY
RIGHT-OF-WAY SERVICES

ROW ID NO. 2016-072

SCALE: 1"=80'

EXHIBIT B
SHEET 1 OF 5

PROJECT: PRADO BASIN PARCEL 24-009

PREPARED BY:
Page 10 of J. MORENO

SKETCH TO ACCOMPANY LEGAL DESCRIPTION



N. LINE OF FRAC.
S7-T3S-R7W, SBB&M

N. 1/4 COR OF FRAC.
S7-T3S-R7W, SBB&M

FR. S7
T3S, R7W
SBB&M

GENERAL N'LY LINE OF
DIRECTOR'S DEED 8112-1042 O.R.

APN:
1057-263-03

E01PD-24-009
PARCEL 1

POINT "A" PER DIRECTOR'S DEED
8112-1042 O.R.

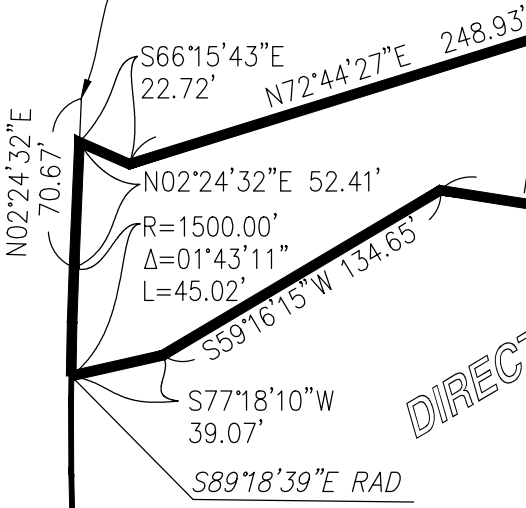

DIRECTOR'S

APN:
1057-263-02

8112-1042 O.R.

W'LY LINE OF DIRECTOR'S DEED
8112-1042 O.R.

DEED

POB

E. LINE OF FRAC.
S7-T3S-R7W, SBB&M

SEE SHEET 3

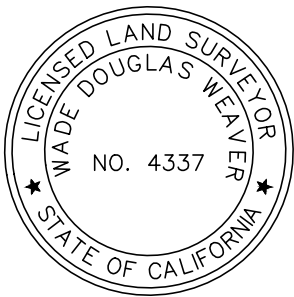

() PER DIRECTOR'S DEED IN BOOK 8112, PAGE 1042 O.R.



OC PUBLIC WORKS
OC SURVEY
RIGHT-OF-WAY SERVICES

ROW ID NO. 2016-072

SCALE: 1"=80'

EXHIBIT B
SHEET 2 OF 5

PROJECT: PRADO BASIN PARCEL 24-009

Page 11 of 11 PREPARED BY:
J. MORENO



SEE SHEET 2

GENERAL N'LY LINE OF DIRECTOR'S DEED 8112-1042 O.R.

DIRECTOR'S DEED 8112-1042 O.R.

FR. S7 T3S, R7W SBB&M

E01PD-24-009 PARCEL 2

APN: 1057-263-02

SEE SHEET 4

() PER DIRECTOR'S DEED IN BOOK 8112, PAGE 1042 O.R.

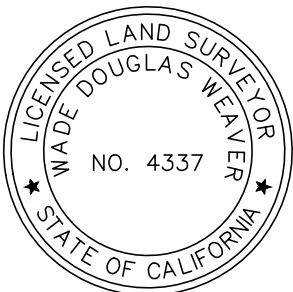

N19°04'59"W
46.19'

N57°58'19"W
101.56'

N77°58'46"W
73.40'

S88°52'50"W
67.13'

N52°05'30"E
316.72'

S01°49'47"W

306.24'

(N01°50'15"E 1529.69')

237.11'

S01°49'47"W

E. LINE OF FRAC. S7-T3S-R7W, SBB&M

POC

TPOB



OC PUBLIC WORKS
OC SURVEY
RIGHT-OF-WAY SERVICES

ROW ID NO. 2016-072

SCALE: 1"=80'

EXHIBIT B
SHEET 3 OF 5

PROJECT: PRADO BASIN PARCEL 24-009

PREPARED BY:
Page 12 of J. MORENO

SEE SHEET 3

GENERAL N'LY LINE OF DIRECTOR'S DEED 8112-1042 O.R.



DIRECTOR'S DEED
8112-1042 O.R.

APN:
1057-263-02

FR. S7
T3S, R7W
SBB&M

E01PD-24-009
PARCEL 3

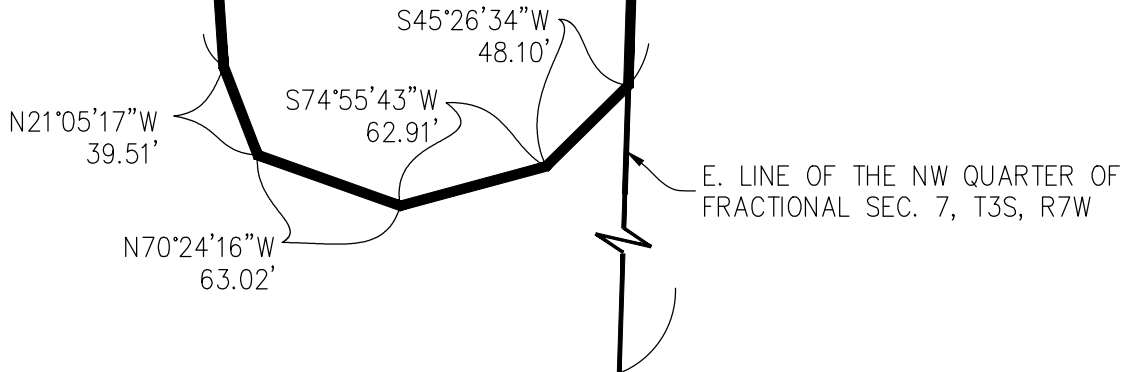

E. LINE OF THE NW QUARTER OF FRACTIONAL SEC. 7, T3S, R7W

SEE SHEET 5

() PER DIRECTOR'S DEED IN BOOK 8112, PAGE 1042 O.R.

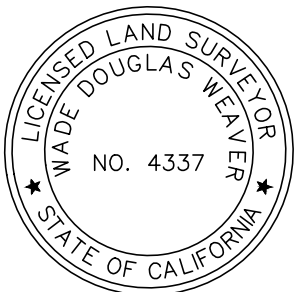

OC PUBLIC WORKS
OC SURVEY
RIGHT-OF-WAY SERVICES

ROW ID NO. 2016-072

SCALE: 1"=80'

EXHIBIT B
SHEET 4 OF 5

PROJECT: PRADO BASIN PARCEL 24-009

PREPARED BY:
Page 13 of 14 J. MORENO



SEE SHEET 4

GENERAL N'LY LINE OF DIRECTORS DEED 8112-1042 O.R.

DIRECTORS DEED 8112-1042 O.R.

APN:

1057-263-02

W'LY LINE OF DIRECTOR'S DEED. 8112-1042 O.R.

STATE HIGHWAY 71
(S19°28'45"E
922.43')

N82°05'34"W
35.37'

FR. S7
T3S, R7W
SBB&M

N52°36'45"W
198.09'

E01PD-24-009
PARCEL 4

191.17'

S19°31'25"E
922.43')

S78°09'54"E
113.40'

N53°05'03"E
19.27'

APN:

1057-263-05

GENERAL S'LY LINE OF DIRECTORS DEED 8112-1042 O.R.

(N01°50'15"E 1529.69')

E. LINE OF THE NW QUARTER OF FRACTIONAL SEC. 7, T3S, R7W

POB

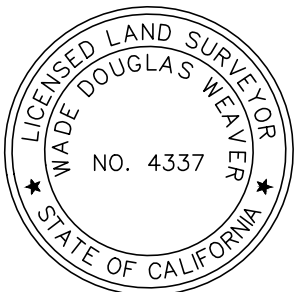

() PER DIRECTOR'S DEED IN BOOK 8112, PAGE 1042 O.R.



OC PUBLIC WORKS
OC SURVEY
RIGHT-OF-WAY SERVICES

ROW ID NO. 2016-072

SCALE: 1"=80'

EXHIBIT B
SHEET 5 OF 5

PROJECT: PRADO BASIN PARCEL 24-009

PREPARED BY:
Page 14 of J. MORENO

**NOTICE OF INTENTION OF THE BOARD OF SUPERVISORS
OF THE COUNTY OF ORANGE, CALIFORNIA, ACTING AS THE
GOVERNING BOARD OF THE ORANGE COUNTY FLOOD CONTROL
DISTRICT, TO CONSIDER FOR ADOPTION A RESOLUTION DETERMINING
THE NECESSITY OF ACQUISITION BY EMINENT DOMAIN OF REAL
PROPERTY**

YOU ARE HEREBY NOTIFIED, pursuant to Code of Civil Procedure section 1245.235, that the Board of Supervisors of the County of Orange (the “Board”), acting as the governing board of the Orange County Flood Control District (the “District”), intends to consider for adoption a resolution of necessity (the “Resolution”), a copy of which as proposed is attached to this Notice, determining the necessity to acquire, through eminent domain proceedings, an easement for flowage purposes over certain real property more specifically described below (the “Subject Property Interests”) – for purposes of the District’s Santa Ana River Mainstem/Prado Dam project (the “Project”). The Subject Property Interests consist of the following:

A perpetual right, power, privilege and easement in, on, over, under, and across the surface of that real property legally described by Exhibit A and depicted on Exhibit B to the proposed Resolution, consisting of project parcel no. E01PD-24-011, which is a portion of San Bernardino County Assessor’s Parcel Number (“APN”) 1057-263-04, located at Pomona Rincon Road and State Route 71, Chino, California (the “Easement Area”), to overflow, flood and/or submerge such real property including the right to cause, without limitation, erosion and/or deposition and associated damages to said Easement Area and any and all structures and improvements situated thereon, in connection with the operation, maintenance, repair, rehabilitation, restoration and improvement of the Prado Dam and reservoir/basin, together with all right, title and interest in and to the structures and improvements now situated on said Easement Area. No structures for human habitation shall be constructed or maintained on the Easement Area. No other structures shall be constructed or maintained within the Easement Area, except as may be approved in writing by the authorized representative of the easement holder. No excavation, drilling or mining shall be conducted, and no landfill placed on the Easement Area without easement

Resolution No._____, Item No._____
Santa Ana River Mainstem/Prado Dam Project
Acquisition by Eminent Domain of Real Property for Flood Control Purposes

holder approval as to the location and method of excavation, drilling, mining, and/or placement of landfill. The Subject Property Interests are subject to existing easements for public roads and highways, public utilities, railroads and pipelines; reserving, however, to underlying fee owner all such rights and privileges as may be used without abridging the rights and easement hereby acquired, and provided that any use of the Easement Area shall be subject to all applicable laws including, but not limited, to laws regarding the environment.

The Subject Property Interests are being considered for acquisition through eminent domain proceedings because District staff believes they are required for the essential flood control purposes of the District with respect to the District's Project; that if the Subject Property Interests were not acquired, the Project could not proceed as planned, which in turn would result in inadequate flood protection downstream of the Prado Dam, potential flooding of, or damage to, State Route 91, and a significant risk of property damage, personal injury and/or loss of life suffered by those downstream in Orange County; and that it is also necessary that the District acquire the Subject Property Interests because that area will itself be exposed to a greater risk of inundation as a result of the increased capacity of the Project reservoir.

YOU ARE HEREBY NOTIFIED that the public hearing by the Board to consider adoption of the Resolution is set for 9:30 a.m. (or as soon thereafter as the Board meeting reaches the agenda item relating to this public hearing) on April 13, 2021, at the Board of Supervisors' Hearing Room, First Floor, County Hall of Administration, 333 W. Santa Ana Blvd., Santa Ana, California.

YOU ARE HEREBY FURTHER NOTIFIED that you must file a written request to appear and be heard within fifteen (15) days of the mailing of this Notice by filing or delivering a written request to the address below if you desire to appear and be

Resolution No._____, Item No.____
 Santa Ana River Mainstem/Prado Dam Project
 Acquisition by Eminent Domain of Real Property for Flood Control Purposes

heard on: (1) whether *the public interest and necessity require the Project*; (2) *whether the Project is planned or located in the manner that will be most compatible with the greatest public good and the least private injury*; (3) *whether the Subject Property Interests sought to be acquired are necessary for the Project*; and (4) *whether the offer required by section 7267.2 of the Government Code has been made to the owner of record.*

Clerk of the Board of Supervisors
Post Office Box 687
Hall of Administration, Fourth Floor
333 W. Santa Ana Blvd.
Santa Ana, California 92702

You may use the following page of this Notice for this purpose to notify the Board of Supervisors of your intent and desire to be heard. Your failure to file a written request to appear and be heard within fifteen (15) days after this Notice was mailed may result by law in a waiver of your right to be heard. For further information, please contact Robin Stieler, Clerk of the Board of Supervisors at (714) 834-3324.

**REQUEST TO BE HEARD ON RESOLUTION DETERMINING THE
NECESSITY TO ACQUIRE AND CONDEMN, THROUGH EMINENT DOMAIN,
REAL PROPERTY FOR THE SANTA ANA RIVER MAINSTEM/ PRADO DAM
PROJECT**

Name _____

Address _____

Telephone Number _____

Dated: _____

(Signature)

Resolution No._____, Item No.____
Santa Ana River Mainstem/Prado Dam Project
Acquisition by Eminent Domain of Real Property for Flood Control Purposes

DECLARATION OF MAILING

_____, Clerk of the Board of Supervisors
 (Name) (Title)

on behalf of the County of Orange, CEO Real Estate Department, hereby declares as follows:

That on March 30, 2021, I mailed, postage prepaid, a copy of the attached NOTICE OF INTENTION OF THE BOARD OF SUPERVISORS OF THE COUNTY OF ORANGE, CALIFORNIA, ACTING AS THE GOVERNING BOARD OF THE ORANGE COUNTY FLOOD CONTROL DISTRICT, TO CONSIDER FOR ADOPTION A RESOLUTION DETERMINING THE NECESSITY OF ACQUISITION BY EMINENT DOMAIN OF REAL PROPERTY to the record owner of the real property which may be acquired and whose names and addresses appear on the last equalized assessment rolls. The names and addresses of all persons the attached Notice was mailed to are as follows:

Notice Recipients – Names and Addresses	
	Henry Cruz and Virginia Cruz 5865 Panama Drive Buena Park, CA 90620
	Brad Kuhn, Attorney at Law, Nossaman LLP 18101 Von Karman Avenue, Suite 1800 Irvine, CA 92612

I declare under penalty of perjury under the laws of the State of California that the foregoing is true and correct to the best of my knowledge.

EXECUTED at Santa Ana, California, this ____ day of _____, 2020.

Resolution No._____, Item No.____
 Santa Ana River Mainstem/Prado Dam Project
 Acquisition by Eminent Domain of Real Property for Flood Control Purposes

(Signature)

Resolution No._____, Item No.____
Santa Ana River Mainstem/Prado Dam Project
Acquisition by Eminent Domain of Real Property for Flood Control Purposes

EXHIBIT A**LEGAL DESCRIPTION**

Santa Ana River – Prado Dam Basin

Facility No: E01PD

Parcel No.: 24-011

That portion of Fractional Section 7. Township 3 South, Range 7 West, San Bernardino Meridian, in the City of Chino Hills, County of San Bernardino, State of California, according to the United States Government Township Plat thereof, described in a Director's Deed recorded June 11, 1973 in Book 8201, Page 907 of Official Records in the office of the County Recorder of said County lying northeasterly, easterly and southeasterly of the follow described line:

BEGINNING at the northerly terminus of that certain course described as having a bearing of South 17°43'00" West and a length of 249.17 feet in the westerly line of said Director's Deed, said northerly terminus being a point in the North line of said Fractional Section 7, distant along said North line North 88°50'18" West 519.32 feet from the north quarter corner of said section, said point also being the Northeasterly corner of that certain parcel of land secondly described in Deed to the State of California, in Book 2417 of Official Records, Page 574, in the Office of the County Recorder of said county;

thence along said westerly line of Director's Deed, said line also being the easterly line of said parcel to the State of California, South 17°44'17" West 151.76 feet;

thence leaving said westerly line, South 35°56'23" East 90.17 feet;

thence South 04°04'02" West 95.90 feet;

thence South 19°11'27" West 164.84 feet;

thence South 36°13'20" West 57.44 feet to a point on the westerly line of the land described in said Director's Deed, said point being measured along said westerly line a distance of 114.48 feet from the most southerly corner of said land described in Director's Deed;

thence along said westerly line of the land described in said Director's Deed South 08°02'19" East 114.48 feet to the most southerly corner of said land described in Director's Deed;

thence along the southeasterly, northeasterly and northerly lines of said Director's Deed the following five (5) courses:

- 1) North 31°08'07" East 156.48 feet;
- 2) North 25°04'17" East 312.55 feet;
- 3) North 24°04'23" West 227.70 feet;

4) North 82°57'03" West 26.10 feet to a point on the north line of said section, said point being measured along said north line a distance of 22.34 feet from the northerly terminus of that certain course described as having a bearing of South 17°43'00" West and a length of 249.17 of said Director's Deed;

5) North 88°50'18" West 22.34 feet along said north section line to the **POINT OF BEGINNING**;

Containing an area of 57,853 Square Feet, more or less.

ALL DISTANCES SHOWN ARE GRID, UNLESS OTHERWISE NOTED. DIVIDE A GRID DISTANCE BY 0.9999880 TO OBTAIN A GROUND DISTANCE

See EXHIBIT B attached and by reference made a part hereof.

APPROVED

Kevin Hills, County Surveyor, L.S. 6617



_____ Date: 9/2/2020

By: Wade Douglas Weaver, L.S. 4337

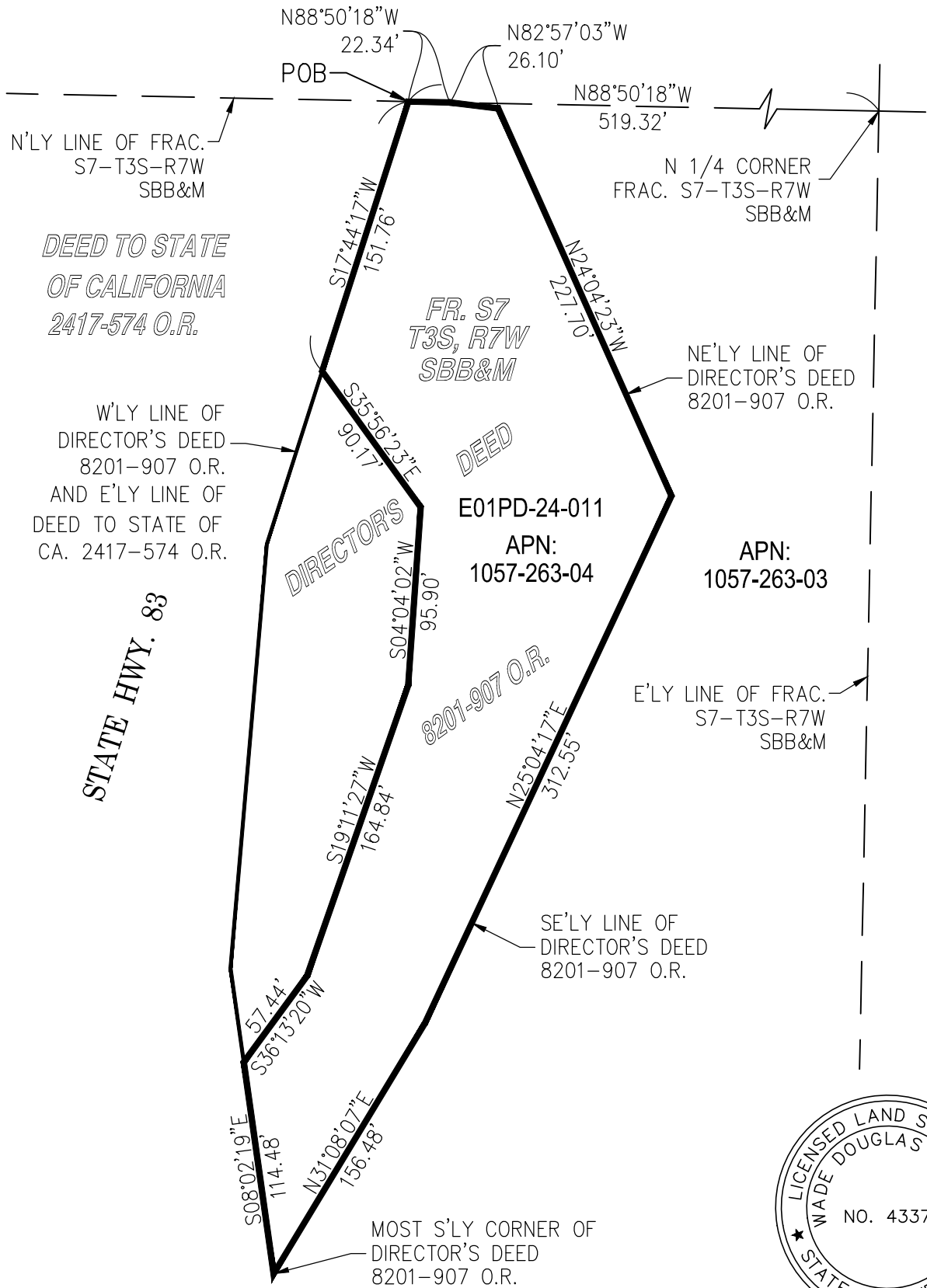

DEED TO STATE OF CALIFORNIA 2417-574 O.R.

W'LY LINE OF DIRECTOR'S DEED 8201-907 O.R. AND E'LY LINE OF DEED TO STATE OF CA. 2417-574 O.R.

STATE HWY. 83

DIRECTOR'S DEED E01PD-24-011 APN: 1057-263-04

APN: 1057-263-03

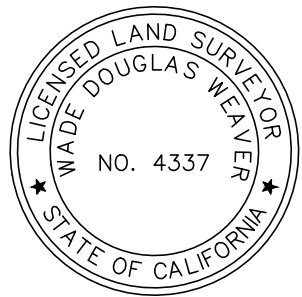

OC PUBLIC WORKS
OC SURVEY
RIGHT-OF-WAY SERVICES

ROW ID NO. 2016-072

SCALE: 1"=80'

EXHIBIT B
SHEET 1 OF 1

PROJECT: PRADO BASIN PARCEL 24-011

PREPARED BY: J. MORENO

APR 07 2021



OFFICE OF THE COUNTY COUNSEL
COUNTY OF ORANGE

333 West Santa Ana Boulevard, Suite 407
Santa Ana, California 92701
Direct No.: (714) 834-3303
E-Mail: leon.page@coco.ocgov.com

LEON J. PAGE
COUNTY COUNSEL

Agenda Item No. SCS- 2
April 13, 2021

M E M O R A N D U M

April 6, 2021

TO: Robin Stieler, Clerk of the Board of Supervisors
FROM: Leon J. Page, County Counsel
SUBJECT: Request for Supplemental Closed Session

I am requesting a supplemental closed session on Tuesday, April 13, 2021, to discuss with the Board the status of existing litigation, pursuant to Government Code section 54956.9(d)(1).

Accordingly, please prepare the Agenda Item to read:

“CONFERENCE WITH LEGAL COUNSEL --
EXISTING LITIGATION Pursuant to Government Code Section
54956.9(d)(1).
Name of Case: *Mark Chew v. County of Orange*
WCAB Case Number: unassigned

RECOMMENDED ACTION: Conduct Closed Session.”

Thank you.

A handwritten signature in cursive script that reads "Leon Page", positioned above a horizontal line.

LJP:jb

cc: Members of the Board of Supervisors
Frank Kim, CEO



RECEIVED
CLERK OF THE BOARD

APR 07 2021

OFFICE OF THE COUNTY COUNSEL
COUNTY OF ORANGE

333 West Santa Ana Boulevard, Suite 407
Santa Ana, California 92701
Direct No.: (714) 834-3303
E-Mail: leon.page@coco.ocgov.com

LEON J. PAGE
COUNTY COUNSEL

Agenda Item No. SCS- 3
April 13, 2021

M E M O R A N D U M

April 7, 2021

TO: Robin Stieler, Clerk of the Board of Supervisors
FROM: Leon J. Page, County Counsel
SUBJECT: Request for Supplemental Closed Session

I am requesting a supplemental closed session to be held on Tuesday, April 13, 2021, for the Board to consider anticipated litigation pursuant to Government Code section 54956.9(d)(2).

Accordingly, please prepare the Agenda Item to read:

“CONFERENCE WITH LEGAL COUNSEL –
ANTICIPATED LITIGATION – SIGNIFICANT EXPOSURE TO
LITIGATION pursuant to Government Code section
54956.9(d)(2).
Number of Cases: Four Cases.

RECOMMENDED ACTION: Conduct Closed Session.”

Thank you.

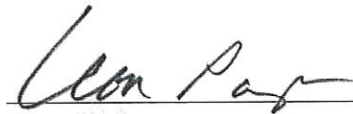

LJP:jb

cc: Members of the Board of Supervisors
Frank Kim, CEO



RECEIVED
CLERK OF THE BOARD

APR 07 2021

OFFICE OF THE COUNTY COUNSEL
COUNTY OF ORANGE

333 West Santa Ana Boulevard, Suite 407
Santa Ana, California 92701
Direct No.: (714) 834-3303
E-Mail: leon.page@coco.ocgov.com

LEON J. PAGE
COUNTY COUNSEL

Agenda Item No. SCS- 4
April 13, 2021

M E M O R A N D U M

April 7, 2021

TO: Robin Stieler, Clerk of the Board of Supervisors
FROM: Leon J. Page, County Counsel
SUBJECT: Request for Supplemental Closed Session

I am requesting a supplemental closed session on Tuesday, April 13, 2021, to discuss with the Board the status of existing litigation, pursuant to Government Code section 54956.9(d)(1).

Accordingly, please prepare the Agenda Item to read:

“CONFERENCE WITH LEGAL COUNSEL –
EXISTING LITIGATION Pursuant to Government Code Section
54956.9(d)(1).
Name of Case: *City of Santa Ana v. County of Orange*,
United States District Court Case No. 8:20-cv-00069-DOC-DFM.

RECOMMENDED ACTION: Conduct Closed Session.”

Thank you.

LJP:MVR:jb

cc: Members of the Board of Supervisors
Frank Kim, CEO



RECEIVED
CLERK OF THE BOARD

APR 07 2021

OFFICE OF THE COUNTY COUNSEL
COUNTY OF ORANGE

333 West Santa Ana Boulevard, Suite 407
Santa Ana, California 92701
Direct No.: (714) 834-3303
E-Mail: leon.page@coco.ocgov.com

LEON J. PAGE
COUNTY COUNSEL

Agenda Item No. SCS- 5
April 13, 2021

M E M O R A N D U M

April 7, 2021

TO: Robin Stieler, Clerk of the Board of Supervisors
FROM: Leon J. Page, County Counsel
SUBJECT: Request for Supplemental Closed Session

I am requesting a supplemental closed session on Tuesday, April 13, 2021, to discuss with the Board the status of existing litigation, pursuant to Government Code section 54956.9(d)(1).

Accordingly, please prepare the Agenda Item to read:

“CONFERENCE WITH LEGAL COUNSEL –
EXISTING LITIGATION Pursuant to Government Code Section
54956.9(d)(1).
Name of Case: *Orange County Flood Control District v. John Bos
and Andy Bos, Trustees of the Bos Grandchildrens' Trust, et al.*,
San Bernardino County Superior Court Case No. CIVDS1936248.

RECOMMENDED ACTION: Conduct Closed Session.”

Thank you.

LJP:NMW:jb

cc: Members of the Board of Supervisors
Frank Kim, CEO

APR 12 2021



OFFICE OF THE COUNTY COUNSEL
COUNTY OF ORANGE

333 West Santa Ana Boulevard, Suite 407
Santa Ana, California 92701
Direct No.: (714) 834-3303
E-Mail: leon.page@coco.ocgov.com

LEON J. PAGE
COUNTY COUNSEL

Agenda Item No. SCS- 6
April 13, 2021

MEMORANDUM

April 12, 2021

TO: Robin Stieler, Clerk of the Board of Supervisors
FROM: Leon J. Page, County Counsel
SUBJECT: Request for Supplemental Closed Session; Conference with Legal Counsel –
Initiation of Litigation

In accordance with Government Code section 54954.2(b)(2), and upon a two-thirds vote of the members of the Board of Supervisors present, I am requesting that a supplemental closed session be held on Tuesday, April 13, 2021, for the Board to confer with legal counsel concerning County's involvement in pending litigation to which the County is not presently a party, *City of Santa Ana v. Orange County Association for Mental Health dba Mental Health Association of Orange County*, Orange County Superior Court case no. 30-2020-01124174.

On Friday, April 9, 2021, the undersigned learned that the Mental Health Association of Orange County (MHAOC), a County service provider, is seeking assistance from the County, in the form of a supportive declaration from a County employee, in its defense of a lawsuit filed against the service provider by the City of Santa Ana. According to counsel for MHAOC, the court filing deadline is tomorrow, April 13, 2021. Should the City of Santa Ana prevail in its lawsuit against MHAOC, clients of MHAOC could experience a disruption in service. As the service provider's request for this declaration came to the attention of my office subsequent to the meeting agenda being posted, the Board's immediate action is recommended.

Accordingly, please prepare the Agenda Item to read:

“CONFERENCE WITH LEGAL COUNSEL –
INITIATION OF LITIGATION Pursuant to Government Code
Section 54956.9(d)(4).
Number of Cases: One. *City of Santa Ana v. Orange County
Association for Mental Health dba Mental Health Association of
Orange County*, Orange County Superior Court case no. 30-2020-
01124174.

RECOMMENDED ACTION: Conduct Closed Session
(2/3 vote of the members).”

Thank you.

Leon Page
Digitally signed by Leon Page
DN: cn=Leon Page, o=County Counsel,
email=leon.page@coco.ocgov.com, c=US
Date: 2021.04.12 13:33:20 -07'00'

LJP:jb

cc: Members of the Board of Supervisors
Frank Kim, CEO